

# Installation Note

---

## **Second Source Upgrade Kit**

**To Upgrade Option 145 to 146 or Option 245 to 246**

**Upgrade Kit Order Number: N5230AU-927**

**For N5230A Option 145 or 245 PNA-L (13.5 GHz or 20 GHz, 4-Port,  
Configurable Test Set with Source Attenuator)**



**Upgrade Kit Number: N5230-60112**  
**Agilent Document Number: N5230-90019**

**Printed in USA July 2007**  
**Supersedes Print Date: May 2007**

© Agilent Technologies, Inc. 2006, 2007



N5230-90019

---

## WARRANTY STATEMENT

THE MATERIAL CONTAINED IN THIS DOCUMENT IS PROVIDED “AS IS,” AND IS SUBJECT TO BEING CHANGED, WITHOUT NOTICE, IN FUTURE EDITIONS. FURTHER, TO THE MAXIMUM EXTENT PERMITTED BY APPLICABLE LAW, AGILENT DISCLAIMS ALL WARRANTIES, EITHER EXPRESS OR IMPLIED WITH REGARD TO THIS MANUAL AND ANY INFORMATION CONTAINED HEREIN, INCLUDING BUT NOT LIMITED TO THE IMPLIED WARRANTIES OF MERCHANTABILITY AND FITNESS FOR A PARTICULAR PURPOSE. AGILENT SHALL NOT BE LIABLE FOR ERRORS OR FOR INCIDENTAL OR CONSEQUENTIAL DAMAGES IN CONNECTION WITH THE FURNISHING, USE, OR PERFORMANCE OF THIS DOCUMENT OR ANY INFORMATION CONTAINED HEREIN. SHOULD AGILENT AND THE USER HAVE A SEPARATE WRITTEN AGREEMENT WITH WARRANTY TERMS COVERING THE MATERIAL IN THIS DOCUMENT THAT CONFLICT WITH THESE TERMS, THE WARRANTY TERMS IN THE SEPARATE AGREEMENT WILL CONTROL.

---

## DFARS/Restricted Rights Notice

If software is for use in the performance of a U.S. Government prime contract or subcontract, Software is delivered and licensed as “Commercial computer software” as defined in DFAR 252.227-7014 (June 1995), or as a “commercial item” as defined in FAR 2.101(a) or as “Restricted computer software” as defined in FAR 52.227-19 (June 1987) or any equivalent agency regulation or contract clause. Use, duplication or disclosure of Software is subject to Agilent Technologies’ standard commercial license terms, and non-DOD Departments and Agencies of the U.S. Government will receive no greater than Restricted Rights as defined in FAR 52.227-19(c)(1-2) (June 1987). U.S. Government users will receive no greater than Limited Rights as defined in FAR 52.227-14 (June 1987) or DFAR 252.227-7015 (b)(2) (November 1995), as applicable in any technical data.

---

## Safety Notes

The following safety notes are used throughout this document. Familiarize yourself with each of these notes and its meaning before performing any of the procedures in this document.

---

<b>WARNING</b>	<b>Warning denotes a hazard. It calls attention to a procedure which, if not correctly performed or adhered to, could result in injury or loss of life. Do not proceed beyond a warning note until the indicated conditions are fully understood and met.</b>
----------------	---

---

---

<b>CAUTION</b>	Caution denotes a hazard. It calls attention to a procedure that, if not correctly performed or adhered to, could result in damage to or destruction of the instrument. Do not proceed beyond a caution sign until the indicated conditions are fully understood and met.
----------------	---

---

---

## Getting Assistance from Agilent

By internet, phone, or fax, get assistance with all your test and measurement needs.

### Contacting Agilent

Assistance with test and measurements needs and information on finding a local Agilent office are available on the Web at:

<http://www.agilent.com/find/assist>

If you do not have access to the Internet, please contact your Agilent field engineer.

---

**NOTE** In any correspondence or telephone conversation, refer to the Agilent product by its model number and full serial number. With this information, the Agilent representative can determine whether your product is still within its warranty period.

---

---

## Description of the Upgrade

This upgrade adds a second source to your 13.5 GHz or 20 GHz, 4-port, configurable test set analyzer (N5230A Option 145 or N5230A Option 245). After installation of this upgrade, your analyzer will be an N5230A Option 146 or N5230A Option 246.

---

## About Installing the Upgrade

Products affected . . . . .	N5230A Option 145 or 245 (13.5 GHz or 20 GHz, 4-port, configurable test set with source attenuator) with firmware revision code 7 or higher
Installation to be performed by . . . . .	Agilent service center or personnel qualified by Agilent
Estimated installation time . . . . .	2.0 hours
Estimated adjustment time . . . . .	0.5 hours
Estimated full instrument calibration time . . . .	4.5 hours

## Items Included in the Upgrade Kit

Check the contents of your kit against the following list. If any part is missing or damaged, contact Agilent Technologies. Refer to [“Getting Assistance from Agilent” on page 3](#).

**Table 1 Contents of Upgrade Kit N5230-60112**

Ref Desig.	Description	Qty	Part Number
<b>Assemblies, hardware, and miscellaneous parts are listed here in the order in which they are installed.</b>			
	Installation note (this document)	1	N5230-90019
A14	System motherboard	1	N5230-60086
	Midweb assembly (includes three fans with shields)	1	N5230-60043
	Plenum bracket	1	E8356-00033
A29	Reference switch and wire harness	1	5087-7714
	Reference switch mounting bracket	1	N5230-00007
	Machine screw (to attach reference switch mounting bracket to analyzer)	3	0515-1227
	Machine screw (to attach reference switch to reference switch mounting bracket)	2	0515-1992
	50-ohm load (termination) (for unused A19 MASSQuad ports)	2	1810-0118
	DC block	1	1250-3478
	Limiter	1	N9356-60001
	Cable tie mount (for mounting the limiter)	1	1400-1626
	Cable tie (1 for the limiter and 4 for cable W80)	5	1400-0249
A11	Vertical motherboard	1	N5230-63084
	Machine screw (to attach A11 vertical motherboard to plenum bracket)	6	0515-0372
A17	QABC board	1	N5230-60085
A18	MASSQuad (for A17 QABC board)	1	5087-7294
	Machine screw (to attach A18 MASSQuad to A17 QABC board)	3	0515-0372
A26	Step attenuator (for A17 QABC board)	1	33321-60065
	Machine screw (to attach A26 step attenuator to A17 QABC board)	2	0515-2693
	50-ohm load (termination) (for unused A18 MASSQuad ports)	2	1810-0118
A12	Multiplier board	1	N5230-60098
A13	Fractional-N synthesizer board	1	N5230-60097
	Retainer block (foam pad) (for inside of inner cover)	3	N5230-40001
	Inner cover	1	N5230-00012
	Machine screw (additional screw to attach new inner cover)	1	0515-1227
	Outer cover	1	N5230-00011

**Table 1 Contents of Upgrade Kit N5230-60112**

Ref Desig.	Description	Qty	Part Number
<b>Cables are listed here in numerical order by reference designator.</b>			
W61	RF cable, A13 synthesizer to A12 multiplier	2	N5230-20041
W62			
W63	RF cable, A12 multiplier to A18 MASSQuad	1	N5230-20096
W64	RF cable, A18 MASSQuad to front panel PORT 3 SOURCE OUT	1	N5230-20091
W65	RF cable, A18 MASSQuad to front panel PORT 4 SOURCE OUT	1	N5230-20092
W66	RF cable, A19 MASSQuad to A29 reference switch port 1	1	N5230-20094
W67	RF cable, A18 MASSQuad to A29 reference switch port 2	1	N5230-20095
W68	RF cable, A29 reference switch to limiter	1	N5230-20100
W69	RF cable, DC block to front panel REFERENCE SOURCE OUT	1	N5230-20093
W70	RF cable, flexible, A10 frequency reference to A17 QABC	1	N5230-60039
W71	RF cable, flexible, A17 QABC to A7 synthesizer	1	N5230-60040
W72	RF cable, flexible, A17 QABC to A9 synthesizer	1	N5230-60041
W73	RF cable, flexible, A17 QABC to A13 synthesizer	1	N5230-60042
W74	RF cable, flexible, A17 QABC to A18 MASSQuad	1	N5230-60038
W75	RF cable, flexible, A18 MASSQuad to A17 QABC board	1	N5230-60037
W76	Ribbon cable, A17 QABC to A26 step attenuator	1	8121-0819
	Retainer clip for W76	1	1252-2216
W77	Ribbon cable, A17 QABC to A18 MASSQuad	1	N5230-60027
	Retainer clip for W77	1	1252-2219
W78	RF cable, A18 MASSQuad to A26 step attenuator	1	N5230-20089
W79	RF cable, A26 step attenuator to A18 MASSQuad	1	N5230-20090
W80	RF cable, Front panel REFERENCE RCVR IN to A20 mixer brick (R)	1	N5230-20097

---

## Installation Procedure for the Upgrade

The network analyzer must be in proper working condition prior to installing this option. Any necessary repairs must be made before proceeding with this installation.

---

**WARNING**      **This installation requires the removal of the analyzer's protective outer covers. The analyzer must be powered down and disconnected from the mains supply before performing this procedure.**

---

### Electrostatic Discharge Protection

Protection against electrostatic discharge (ESD) is essential while removing or connecting cables or assemblies within the network analyzer.

Static electricity can build up on your body and can easily damage sensitive internal circuit elements when discharged. Static discharges too small to be felt can cause permanent damage. To prevent damage to the instrument:

- *always* have a grounded, conductive table mat in front of your test equipment.
- *always* wear a grounded wrist strap, connected to a grounded conductive table mat, having a 1 M $\Omega$  resistor in series with it, when handling components and assemblies or when making connections.
- *always* wear a heel strap when working in an area with a conductive floor. If you are uncertain about the conductivity of your floor, wear a heel strap.
- *always* ground yourself before you clean, inspect, or make a connection to a static-sensitive device or test port. You can, for example, grasp the grounded outer shell of the test port or cable connector briefly.

Figure 1 shows a typical ESD protection setup using a grounded mat and wrist strap. Refer to “Tools and Equipment Required for the Installation” on page 7 for part numbers.

**Figure 1**    **ESD Protection Setup**

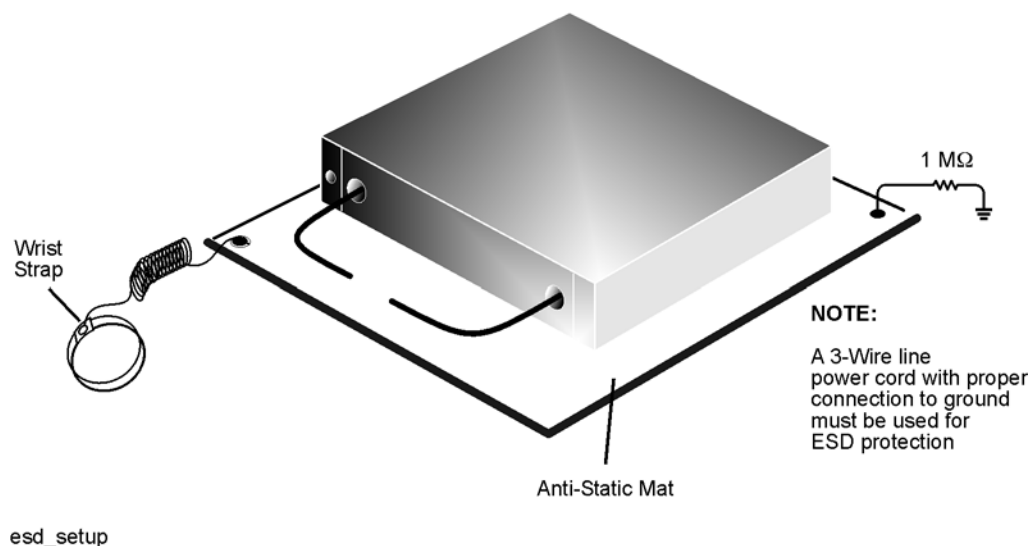

## Tools and Equipment Required for the Installation

Description	Qty	Part Number
T-8 TORX driver (set to 5 in-lbs)	1	N/A
T-10 TORX driver (set to 9 in-lbs)	1	N/A
T-15 TORX driver (set to 14 in-lbs)	1	N/A
T-20 TORX driver (set to 21 in-lbs)	1	N/A
5.5 mm nut driver (set to 9 in-lbs)	1	N/A
1/4-in open end wrench	1	N/A
5/16-in open-end wrench	2	N/A
5/16-in torque wrench (set to 10 in-lbs)	1	N/A
5/16-in torque wrench (set to 21 in-lbs)	1	N/A
1-in torque wrench (set to 72 in-lbs)	1	N/A

---

**CAUTION** Use a 5/16-in torque wrench set to 10 in-lbs on all cable connections except the front-panel cable connectors. Use a 5/16-in torque wrench set to 21 in-lbs for these connections.

---

## ESD Equipment Required for the Installation

Description	Qty	Part Number
ESD grounding wrist strap	1	9300-1367
5-ft grounding cord for wrist strap	1	9300-0980
2 x 4 ft conductive table mat and 15-ft grounding wire	1	9300-0797
ESD heel strap (for use with conductive floors)	1	9300-1308

## Equipment Required for Post-Upgrade Adjustments

Equipment Type	Model or Part Number	Alternate Model or Part Number
Power meter	E4418B/E4419B	E4418A/E4419A
Power sensor, 3.5 mm	E4413A	8485A
Adapter, 3.5 mm (f) to 3.5 mm (f)	83059B	85052-60012
RF cable, 3.5 mm (f) to 3.5 mm (f)	85131C	85131E

## Overview of the Installation Procedure

- Step 1. Remove the Outer and Inner Covers.
- Step 2. Remove the Front Panel.
- Step 3. Replace the A14 System Motherboard and/or the Midweb Assembly (if necessary).
- Step 4. Replace Reference Input Cables to Synthesizer Boards.
- Step 5. Replace the Plenum Bracket (if necessary).
- Step 6. Install the A29 Reference Switch.
- Step 7. Remove the Existing Source Cables and Install Loads.
- Step 8. Install Limiter, DC Block, and A29 Reference Switch Cables.
- Step 9. Install A11 Vertical Motherboard.
- Step 10. Attach A18 MASSQuad and A26 Step Attenuator to the A17 QABC Board.
- Step 11. Install Cables on the A17 QABC Board.
- Step 12. Install the A17 QABC Board.
- Step 13. Install the A12 Multiplier and A13 Synthesizer Boards.
- Step 14. Position Flexible Cables and Reinstall Cable Hold Down Wire.
- Step 15. Reinstall the Front Panel Assembly and Front Panel Jumpers.
- Step 16. Modify the New Inner Cover.
- Step 17. Install the New Inner and Outer Covers.
- Step 18. Enable Option S02.
- Step 19. Perform Post-Upgrade Adjustments and Calibration.



## Step 1. Remove the Outer and Inner Covers

### Remove the Outer Cover

Refer to [Figure 2](#) for this part of the procedure.

---

**CAUTION** Removal of the outer cover is best performed with the analyzer resting on its front handles in the vertical position. *Do not place the analyzer on its front panel without the handles.* This will damage the front panel assemblies.

---

1. Disconnect the power cord (if it has not already been disconnected).
2. With a T-20 TORX driver, remove the strap handles (item ①) by loosening the screws (item ②) on both ends until the handle is free of the analyzer.
3. With a T-20 TORX driver, remove the four rear panel feet (item ③) by removing the center screws (item ④).
4. Slide the four bottom feet (item ⑤) off the cover.
5. Slide the cover off of the frame.

**Figure 2 Outer Cover Removal**

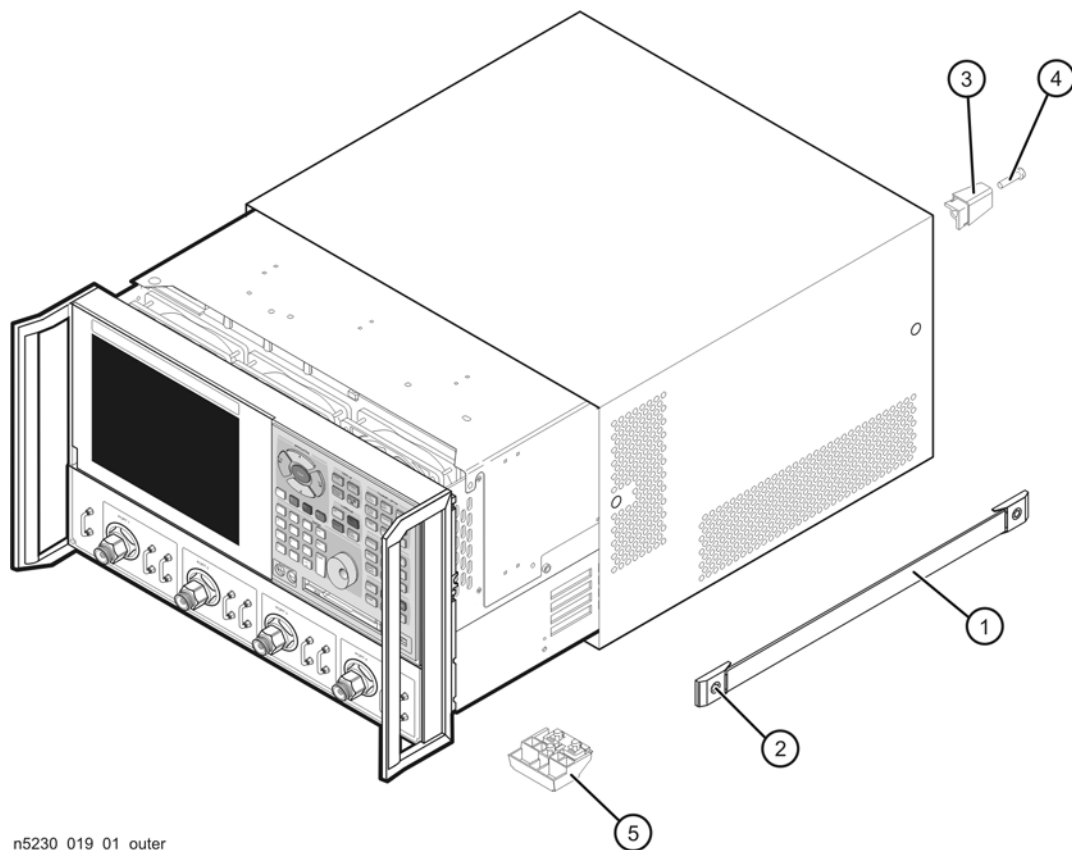

n5230\_019\_01\_outer

## Remove the Inner Cover

Refer to [Figure 3](#) for this part of the procedure.

1. With a T-10 TORX driver, remove the cover attachment screws (item ⑥)
2. Lift off the cover and discard it. It will be replaced with a new one later on in this upgrade procedure.

### Clarification on Cover Replacement

If the attachment screw (item ⑦) is present on your existing analyzer inner cover (five screws total on top of cover), then the cover may be retained as spare parts, as the replacement is identical. If, however, the attachment screw (item ⑦) is not present on your existing inner cover (only four screws on top of cover), then the inner cover must be replaced with the new one provided and the old one discarded. In this case the midweb assembly will also have to be replaced to provide the mounting hole for the extra attachment screw, (item ⑦).

**Figure 3 Inner Cover Removal**

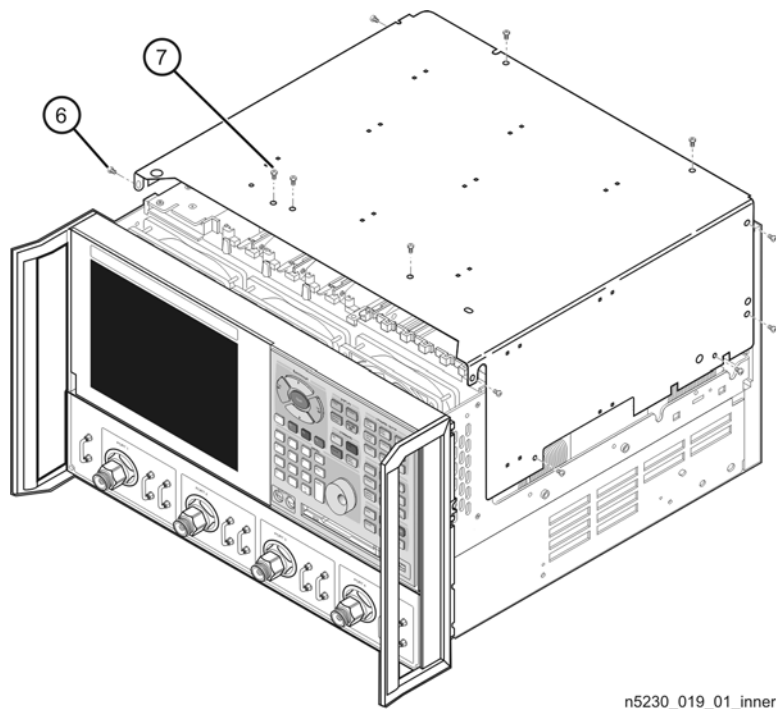

n5230\_019\_01\_inner

## Step 2. Remove the Front Panel

Refer to [Figure 4](#) for this part of the procedure.

1. With a 5/16-inch wrench, remove all the semirigid jumpers (item ①) from the front panel.

---

**CAUTION** Before removing the front panel from the analyzer, lift and support the front of the analyzer chassis.

---

2. With a T-10 TORX driver, remove the eight screws (item ②) from the sides of the frame.
3. Slide the front panel over the test port connectors.
4. Disconnect the front panel interface ribbon cable (item ③). The front panel is now free from the analyzer.

**Figure 4 Front Panel Assembly Removal**

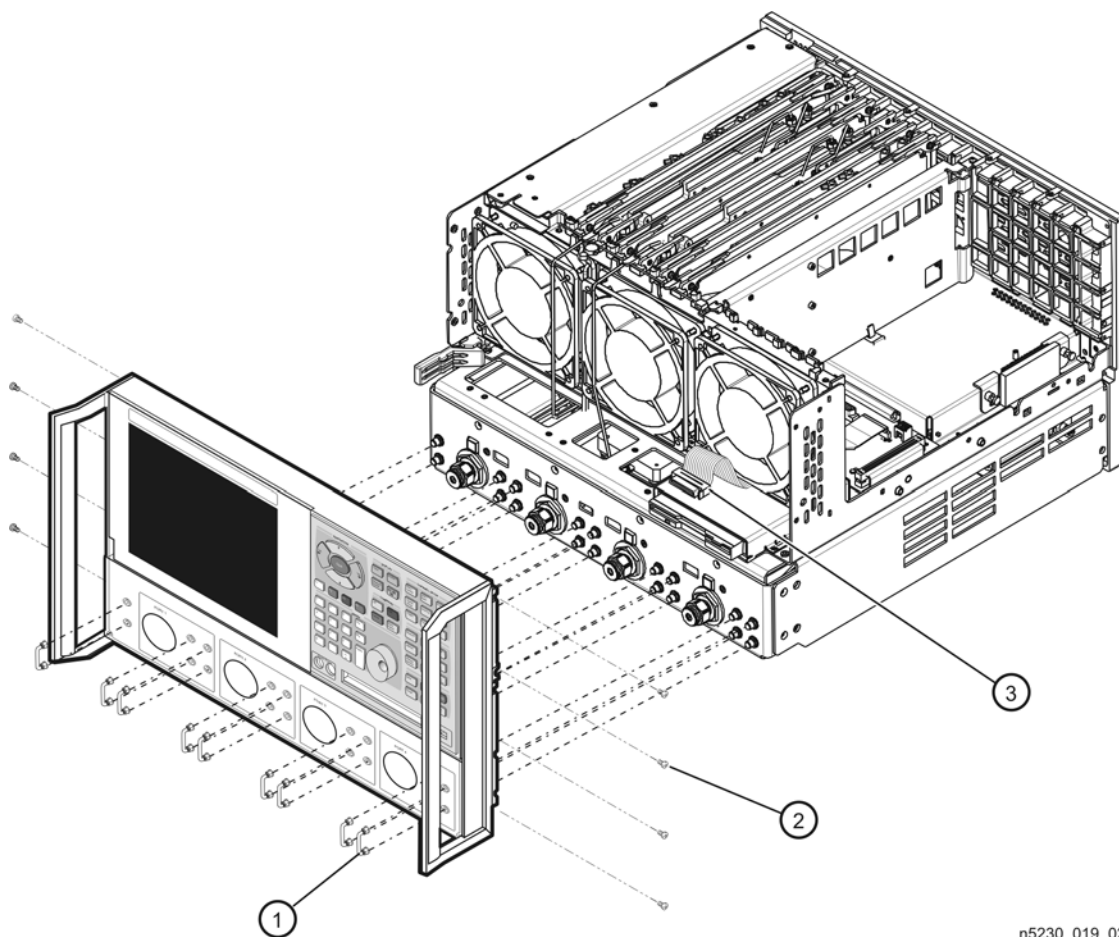

n5230\_019\_02

### Step 3. Replace the A14 System Motherboard and/or the Midweb Assembly (if necessary)

#### Determine if it is Necessary to Replace the A14 System Motherboard

1. Visually locate the barcode label on the A14 system motherboard in the location shown in [Figure 5](#) and note the part number printed on this label.
  - If the part number printed on the barcode label IS N5230-63086, then it is not necessary to replace the A14 system motherboard. Proceed to [“Determine if it is Necessary to Replace the Midweb Assembly”](#) on page 13.
  - If the part number printed on the barcode label IS NOT N5230-63086, then the A14 system motherboard must be replaced. Proceed to [“Determine if it is Necessary to Replace the Midweb Assembly”](#) on page 13.

**Figure 5 A14 System Motherboard Part Number Location**

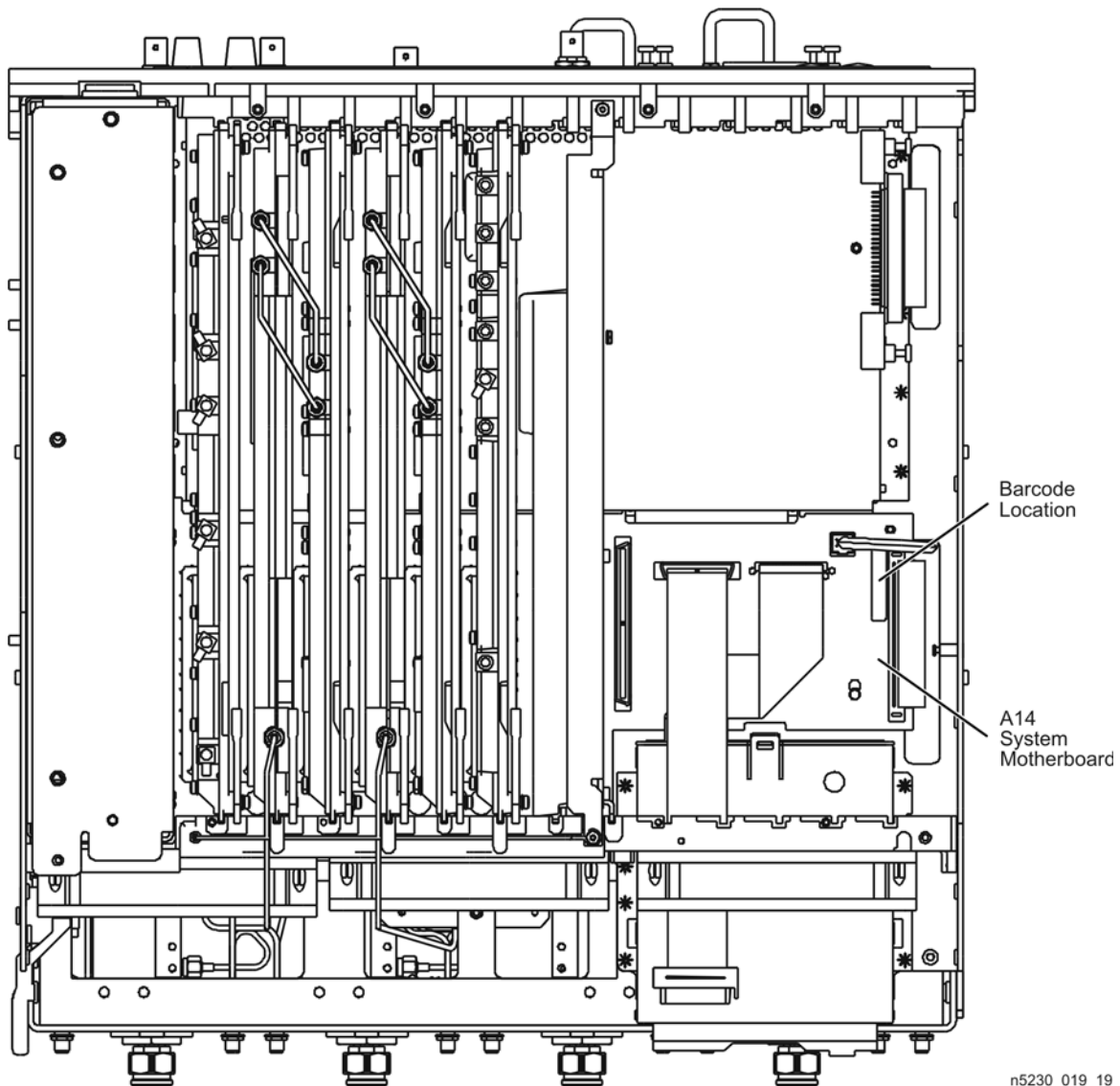

## Determine if it is Necessary to Replace the Midweb Assembly

1. Refer to “Remove the Inner Cover” on page 10.
  - If the attachment screw (item ⑦) WAS PRESENT on your analyzer’s inner cover, then it is not necessary to replace the midweb assembly.
    - If it is also not necessary to replace the A14 system motherboard (See “Determine if it is Necessary to Replace the A14 System Motherboard” on page 12.), then proceed to “Step 4. Replace Reference Input Cables to Synthesizer Boards” on page 32.
    - If it is necessary to replace the A14 system motherboard (See “Determine if it is Necessary to Replace the A14 System Motherboard” on page 12.), then continue with this step in the procedure.
  - If the extra attachment screw (item ⑦) WAS NOT PRESENT on your analyzer’s inner cover, then the midweb assembly must be replaced. Continue with this step in the procedure.

## Remove the A4 Power Supply Assembly

1. With a T-10 TORX driver, remove the five screws (item ①) from the power supply assembly and set them aside for reinstallation later.
2. Lift out and remove the A4 power supply assembly and set it aside for reinstallation later.

**Figure 6 A4 Power Supply Removal**

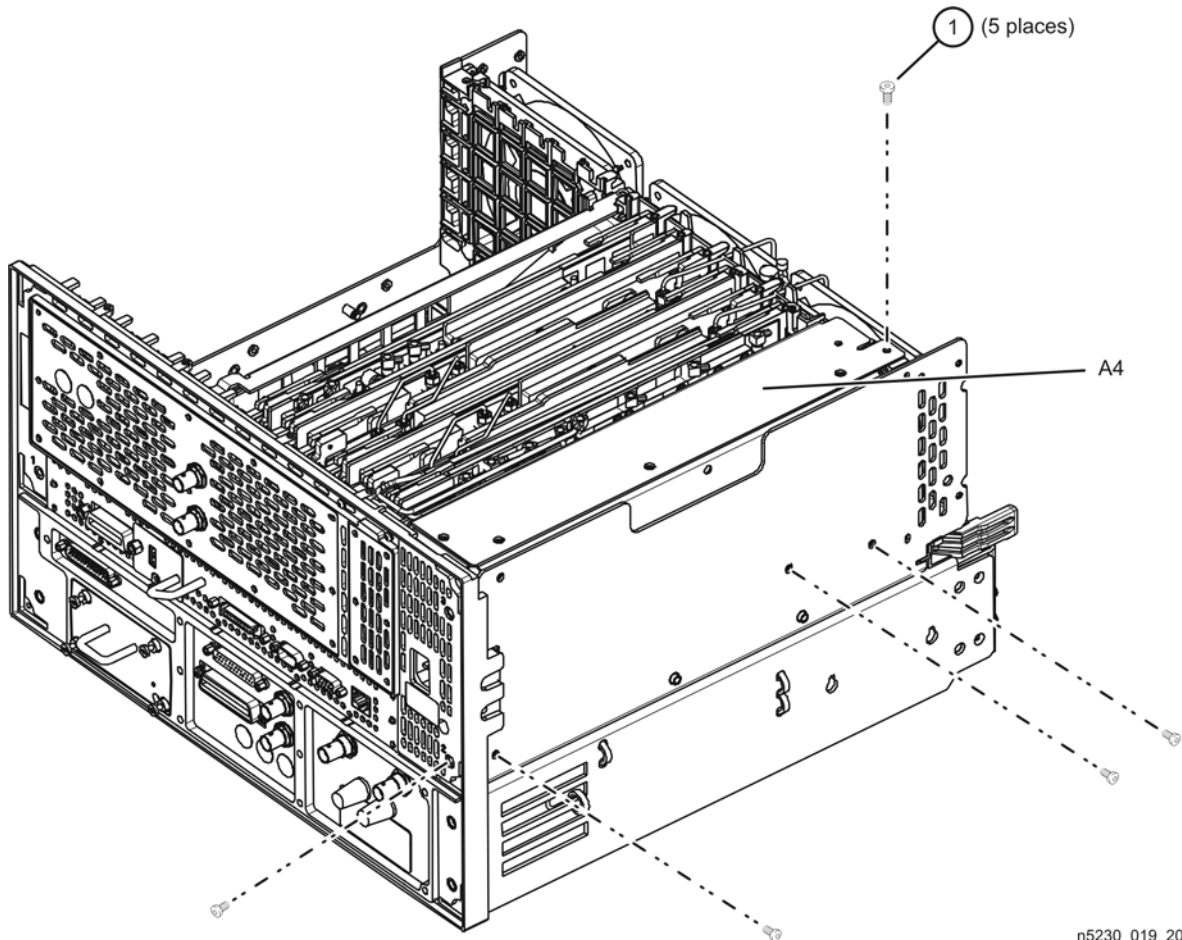

n5230\_019\_20

## Remove the Card Cage Boards (A5 through A10) and the Plenum Bracket

1. Disconnect all cables from the A5, A6, A7, A8, A9, and A10 boards. Refer to [Figure 7](#). Label each cable connection for re-connection later.
2. To remove the boards, lift the two extractors (item ①) located at each end of each board. There is a flexible cable attached to the bottom of the A7 and A9 boards. Disconnect these cables at both ends and discard them; they will be replaced later.
3. Remove all of the boards and set them aside for reinstallation later. Be careful not to damage the top-to-bottom semi-rigid cables.
4. Remove the two plenum bracket screws (item ②). One of these screws also fastens the cable hold down wire. Remove the cable hold down wire and set the screws and cable hold down wire aside for reinstallation later.
5. Remove the plenum bracket and set it aside for possible reinstallation later.

**Figure 7 Card Cage Boards and Plenum Bracket Removal**

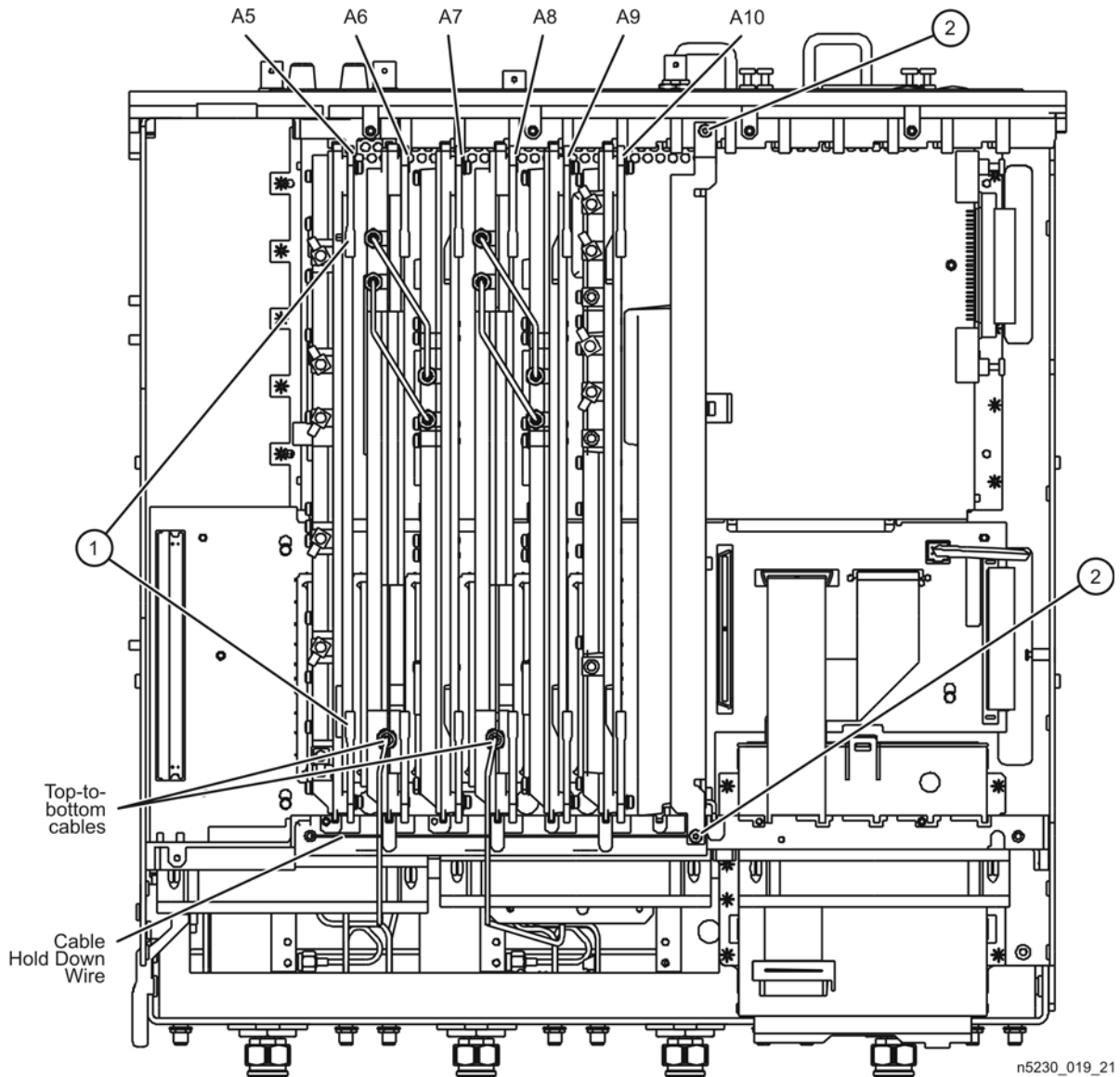

## Remove the A15 CPU Board

1. Disconnect the hard disk drive assembly (HDDA) ribbon cable and interface board from the A15 CPU board by removing the two screws (item ①).
2. With a T-10 TORX driver, remove the 14 screws (item ②) from the rear panel of the A15 CPU board.
3. Gently pull on the finger grip (item ③) to disengage the A15 CPU board from the analyzer.
4. Slide the A15 CPU board out of the analyzer.

**Figure 8 A15 CPU Board Removal**

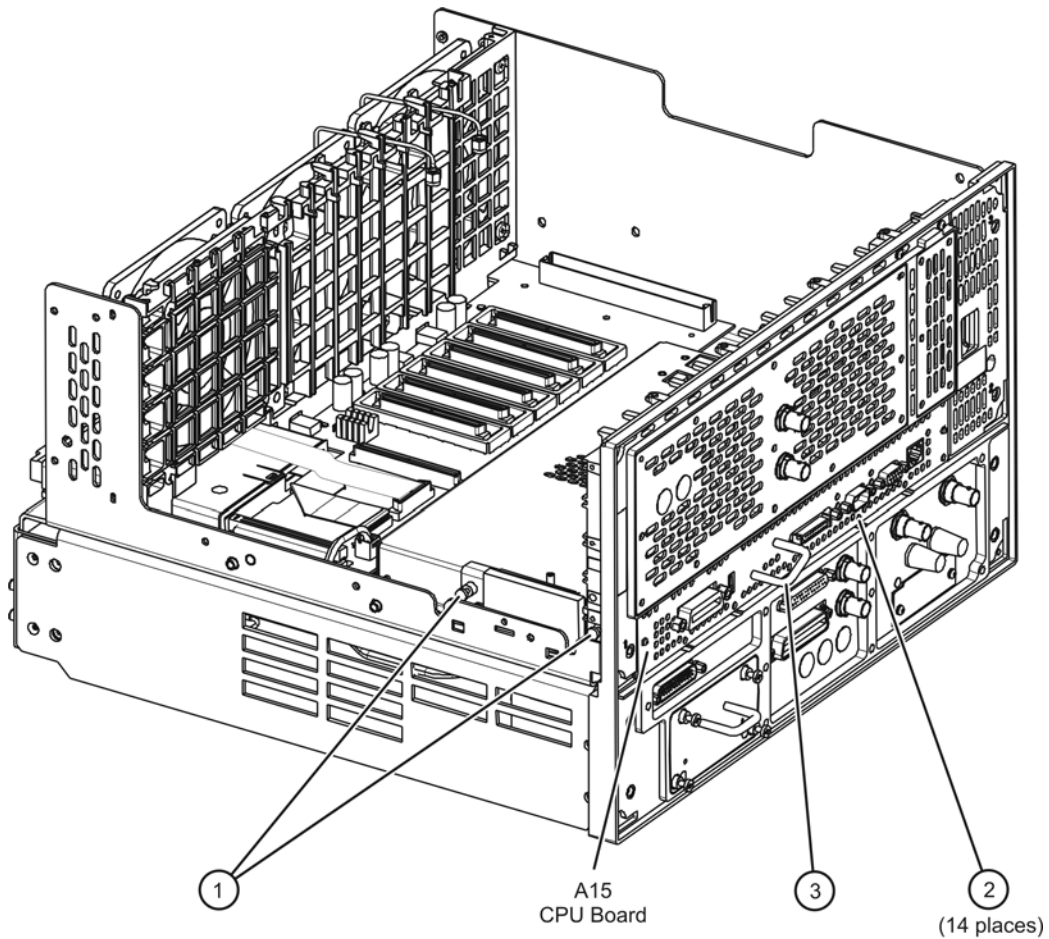

n5230\_019\_22

## Remove the Midweb Assembly

1. Place the analyzer on its right side as shown in [Figure 9](#) so that the interior of the analyzer is accessible from both the top and the bottom.
2. On the bottom side of the analyzer, remove cables W3 and W6. Refer to [Figure 9](#).
  - a. Disconnect cable W3 at the A20 mixer brick and CAREFULLY remove it from the analyzer. Set this cable aside for reinstallation later.
  - b. Disconnect cable W6 from the A19 MASSQuad and CAREFULLY remove it from the analyzer. Set this cable aside for reinstallation later.
3. On the bottom side of the analyzer, remove the A22 test port coupler and coupler block. Refer to [Figure 9](#). This is necessary to gain access to one of the midweb mounting screws.
  - a. With a 5/16 inch wrench, disconnect the semirigid cables (item ①) from the test port coupler.
  - b. With a T-15 TORX driver, remove the four mounting screws (item ②) from the test port coupler.
  - c. With a 1 inch wrench, remove the test port coupler dress nut (item ③) from the front panel. Be careful not to scratch the front panel.

---

**CAUTION** Be careful not to damage the center pins of the semirigid cables. Some flexing of the cables is necessary to remove the assembly. Do not over-bend them.

---

- d. Remove the test port coupler from the analyzer. Observe the **CAUTION** above.
  - e. Remove the test port coupler mounting block by removing the four attachment screws (item ④).
4. On the bottom side of the analyzer, remove the A19 MASSQuad and the MASSQuad mounting block. Refer to [Figure 9](#). This is necessary to gain access to one of the midweb mounting screws.
  - a. With a 5/16 inch wrench, disconnect the seven semirigid cables (item ⑤) from the A19 MASSQuad. Note their location for reinstallation later.
  - b. Disconnect the two flexible cables (item ⑥), and the ribbon cable (item ⑦) from the A19 MASSQuad. Note their location for reinstallation later.
  - c. With a T-10 TORX driver, remove the three mounting screws (item ⑧) from the A19 MASSQuad and set them aside for reinstallation later.

---

**CAUTION** Be careful not to damage the center pins of the semirigid cables. Some flexing of the cables is necessary to remove the assembly. Do not over-bend them.

---

- d. Remove the A19 MASSQuad from the analyzer. Observe the **CAUTION** above. Set this assembly aside for reinstallation later.
  - e. Next, remove the MASSQuad mounting block by removing the three attachment screws (item ⑨). Set the mounting block aside for reinstallation later.



**Figure 9 Midweb Assembly Removal (1)**

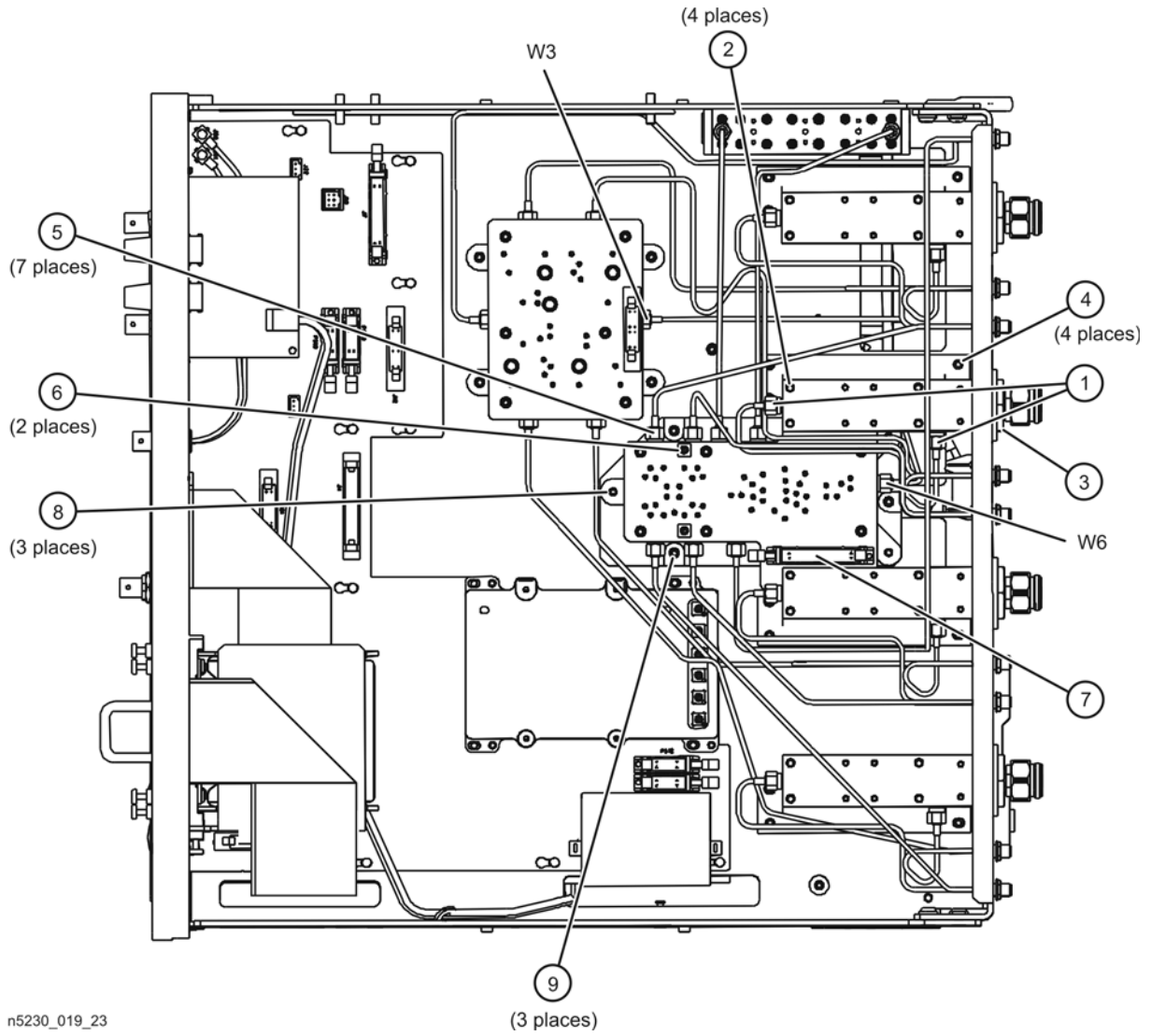

n5230\_019\_23

5. Remove the screws used to secure the midweb assembly.
  - a. With the analyzer still on its right side as shown in [Figure 10](#), remove the three screws (item ⑩) used to secure the bottom of the midweb assembly.

**Figure 10 Midweb Assembly Removal (2)**

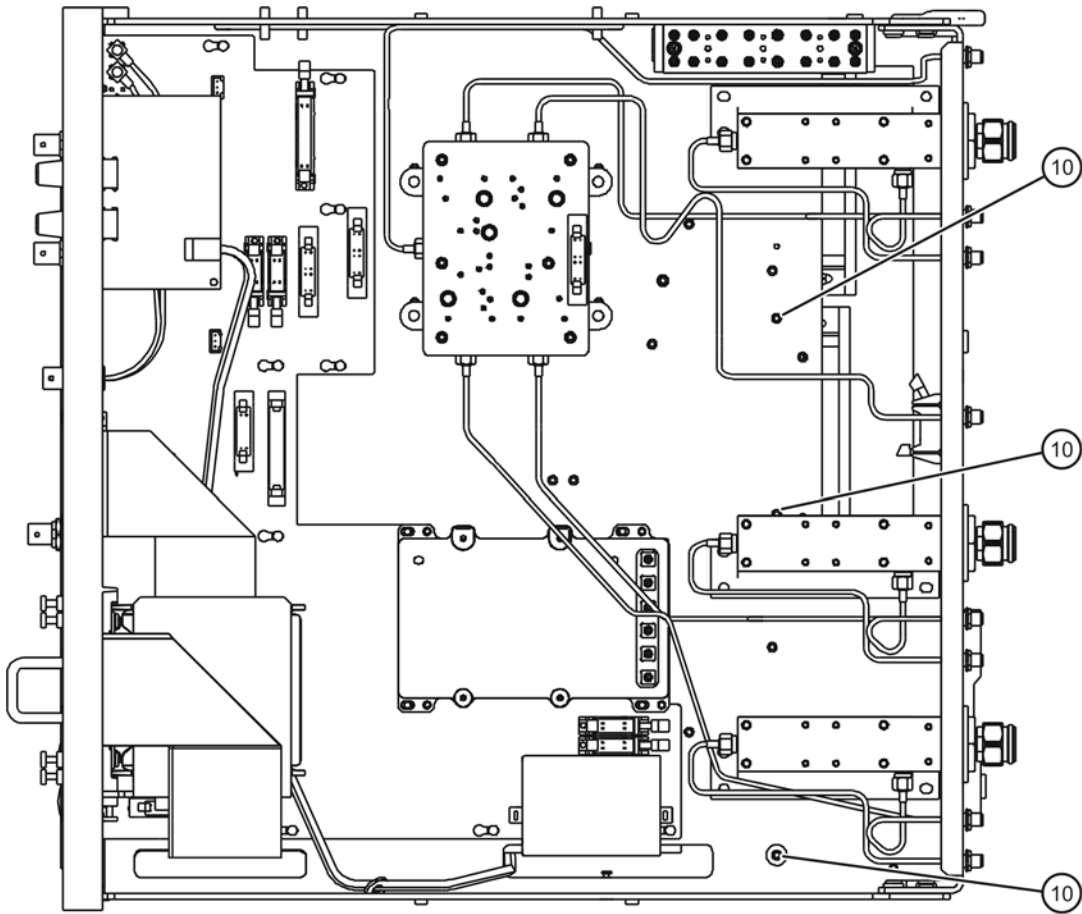

n5230\_019\_24

- b. Position the analyzer top-side-up as shown in [Figure 11](#) and remove the four screws (item ⑪) used to secure the midweb assembly to the side frames.
6. Remove the midweb assembly from the analyzer. Refer to [Figure 11](#).
  - a. Disconnect the power cables (item ⑫) for each of the three fans from the A14 system motherboard.
  - b. Lift and remove the midweb assembly from the analyzer being careful not to damage any adjacent components.
  - c. Discard this midweb assembly; it will be replaced with a new one as part of this upgrade.

### Clarification on Midweb Replacement

If it was determined that the midweb assembly did not need to be replaced (See [“Determine if it is Necessary to Replace the Midweb Assembly” on page 13.](#)) then the existing midweb can be retained as spare parts, as the replacement is identical. If, however, it was determined that the midweb assembly did need to be replaced, only the three fans attached to the old midweb assembly may be retained as spare parts. The midweb itself must be discarded.

**Figure 11 Midweb Assembly Removal (3)**

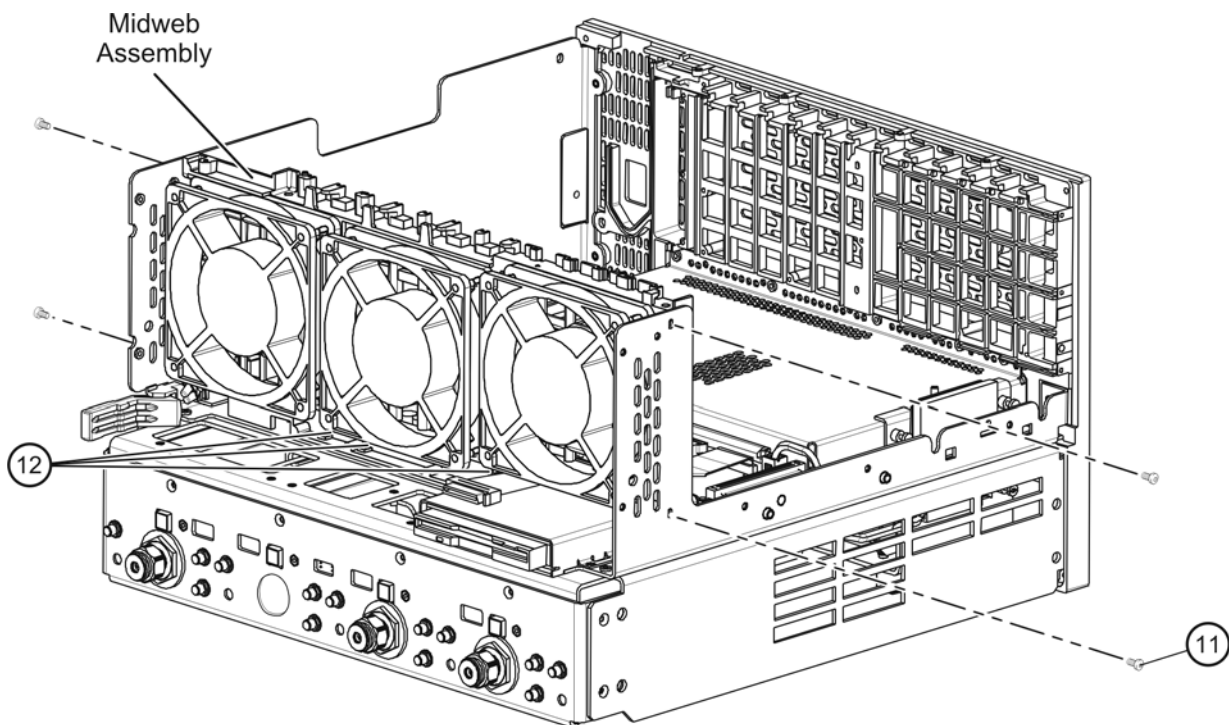

n5230\_019\_25

## Replace the Motherboard (if Necessary)

Refer to [“Determine if it is Necessary to Replace the A14 System Motherboard”](#) on page 12. Refer to [Figure 12](#) for this part of the procedure.

1. Remove the existing A14 system motherboard.
  - a. Remove the power button and power button spring and set them aside for reinstallation later.
  - b. Disconnect the A1 front panel ribbon cable (item ①), the A40 floppy disk drive ribbon cable (item ②), the A16 test set motherboard ribbon cable (item ③), and the USB cable (item ④) from the A14 system motherboard.
  - c. Lift the tab at the rear of the A40 floppy disk drive enclosure and remove the enclosure rear cover. Fold the disk drive ribbon cable (item ②), with the rear cover, back over the top of the disk drive enclosure so that they do not interfere with removing the A14 system motherboard.
  - d. Remove the four screws (item ⑤) that secure the A14 system motherboard and set them aside for reinstallation later.
  - e. Slide the A14 system motherboard toward the front of the analyzer to release it from the guide locking pins and lift it out of the analyzer, being careful not to damage any adjacent components. Discard this motherboard.
2. Install the new A14 system motherboard.
  - a. Position the new A14 system motherboard in the analyzer and align the guide locking pins. Slide the motherboard towards the rear of the analyzer to lock the locking pins.
  - b. Reinstall the four screws (item ⑤) that secure the A14 system motherboard.
  - c. Lift the tab at the rear of the A40 floppy disk drive enclosure and reinstall the enclosure rear cover. Make sure that the four tabs on the bottom of the enclosure rear cover are properly inserted into the slots in the chassis and the tab at the top is properly locked.
  - d. Re-connect the A1 front panel ribbon cable (item ①), the A40 floppy disk drive ribbon cable (item ②), the A16 test set motherboard ribbon cable (item ③), and the USB cable (item ④) to the A14 system motherboard.
  - e. Make sure that the power button LED holder (next to the power switch on the A14 system motherboard) is fully seated on the printed circuit board, then reinstall the power button spring and power button.

**Figure 12 A14 System Motherboard Replacement**

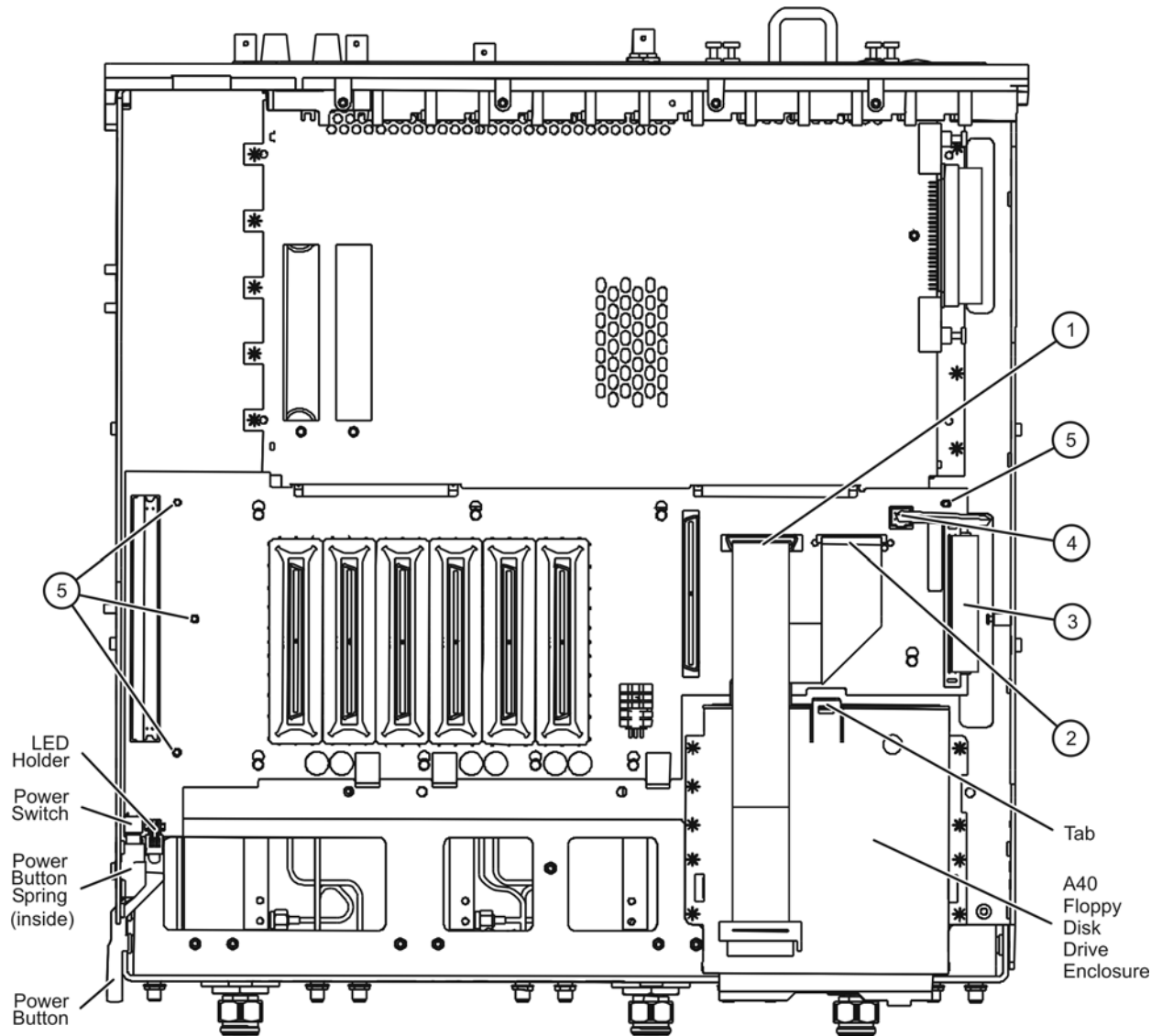

N5230\_019\_26

## Install the New Midweb Assembly

1. Install the new midweb assembly, provided, into the analyzer. Refer to [Figure 13](#).
  - a. Place the midweb assembly into the analyzer being careful not to damage any adjacent components.
  - b. LOOSELY reinstall the four screws (item ⑪) used to secure the midweb assembly to the side frames. DO NOT FULLY TIGHTEN THESE SCREWS AT THIS TIME.
  - c. Re-connect the power cables (item ⑫) for each of the three fans to the A14 system motherboard. It may be necessary to use needle-nose pliers for this.

**Figure 13 Midweb Assembly Reinstallation (1)**

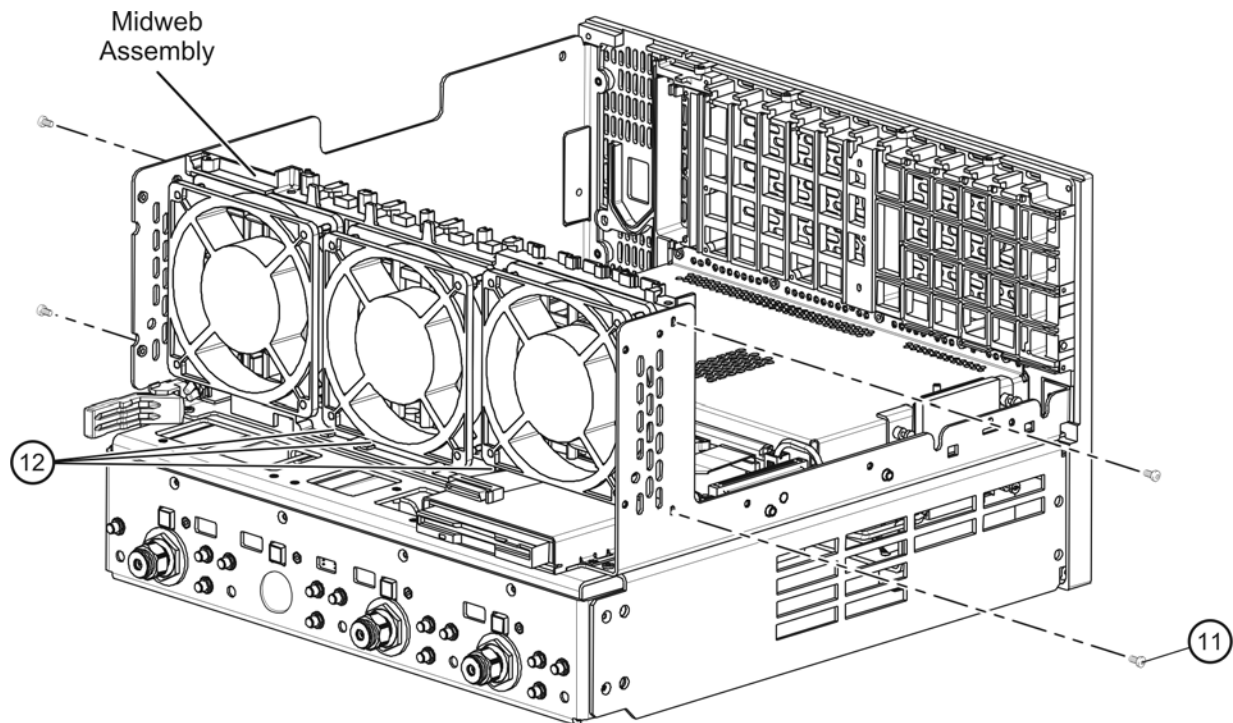

n5230\_019\_25

2. Reinstall the screws used to secure the bottom of the midweb assembly.
  - a. Position the analyzer on its right side as shown in [Figure 14](#).
  - b. Reinstall the three screws (item ⑩) used to secure the bottom of the midweb assembly. Torque these screws to 9 in-lbs.
3. Tighten the screws used to secure the sides of the midweb assembly.
  - a. Position the analyzer top side up as shown in [Figure 13](#).
  - b. Torque the four screws (item ⑪) used to secure the midweb assembly to the side frames to 9 in-lbs.

**Figure 14 Midweb Assembly Reinstallation (2)**

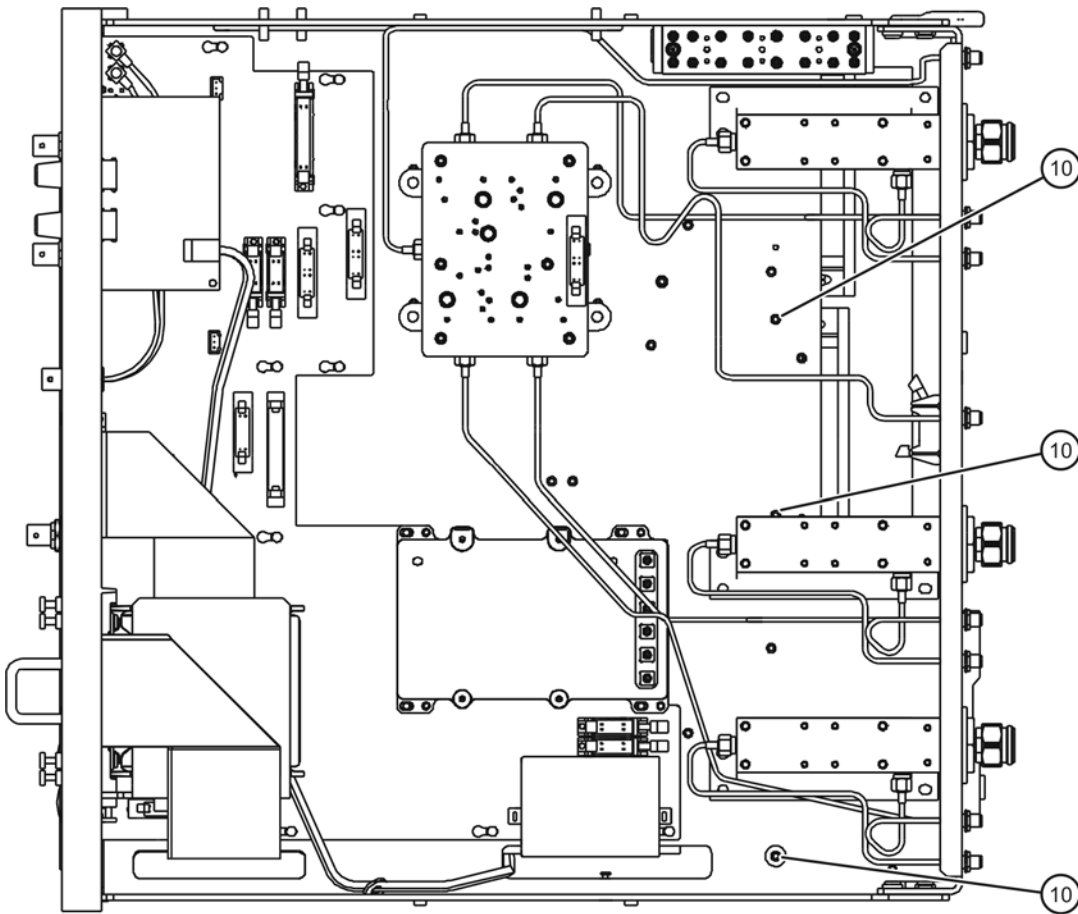

n5230\_019\_24

4. Place the analyzer on its right side as shown in [Figure 15](#) so that the interior of the analyzer is accessible from both the top and the bottom.
5. On the bottom side of the analyzer, reinstall the A19 MASSQuad and the MASSQuad mounting block. Refer to [Figure 15](#).
  - a. Reinstall the MASSQuad mounting block into the analyzer by reinstalling the three attachment screws (item ⑨). Torque to 9 in-lbs.
  - b. Reinstall the A19 MASSQuad into the analyzer by reinstalling the mounting screws (item ⑧). Torque to 9 in-lbs.
  - c. Re-connect the two flexible cables (item ⑥), and the ribbon cable (item ⑦) to the A19 MASSQuad.
  - d. Re-connect the seven semirigid cables (item ⑤) to the A19 MASSQuad. Observe the **CAUTION** below. Torque the connections at the A19 MASSQuad to 10 in-lbs and the connections at the front panel to 21 in-lbs.

---

**CAUTION** Be careful not to damage the center pins of the semirigid cables. Some flexing of the cables is necessary. Do not over-bend them.

---

6. On the bottom side of the analyzer, reinstall the A22 test port coupler and coupler block. Refer to [Figure 9](#).
  - a. Reinstall the test port coupler mounting block by reinstalling the four attachment screws (item ④). Torque to 9 in-lbs.
  - b. Insert the test port coupler into the analyzer in the position shown.
  - c. With a T-15 TORX driver, reinstall the four mounting screws (item ②) in the test port coupler. Torque to 14 in-lbs.
  - d. Install the test port coupler dress nut finger tight. Then, with a 1 inch torque wrench, tighten the dress nut (item ③) to 72 in-lbs. Be careful not to scratch the front panel.

---

**CAUTION** All front panel cable connections must be torqued to 21 in-lbs.

---

- e. Reconnect the two semirigid cables (item ①) to the test port coupler. Torque the connectors at the coupler to 10 in-lbs and the connectors at the front panel to 21 in-lbs.
7. On the bottom side of the analyzer, reinstall cables W3 and W6. Refer to [Figure 15](#).
  - a. **CAREFULLY** insert cable W3 into position and **LOOSELY** re-connect it to the A20 mixer brick. **DO NOT FULLY TIGHTEN THE CONNECTOR AT THIS TIME.**
  - b. **CAREFULLY** insert cable W6 into position and **LOOSELY** re-connect it to the A19 MASSQuad. **DO NOT FULLY TIGHTEN THE CONNECTOR AT THIS TIME.**



**Figure 15 Midweb Assembly Reinstallation (3)**

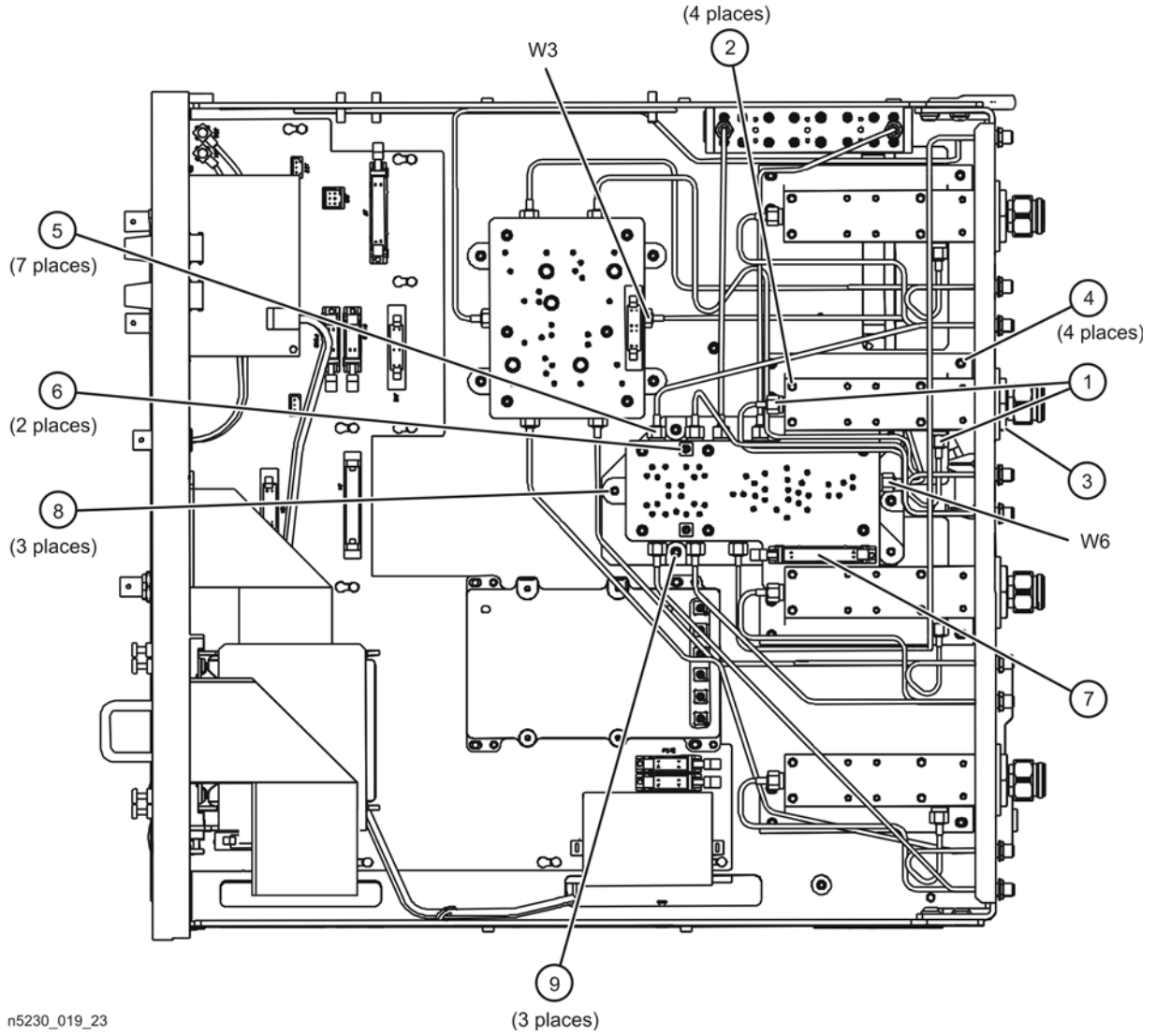

n5230\_019\_23

## Reinstall the A15 CPU Board

1. Slide the A15 CPU board into the analyzer as shown in [Figure 16](#).
2. Gently push on the rear panel to fully seat the A15 CPU board into its connectors.
3. With a T-10 TORX driver, reinstall the 14 screws (item ②) in the rear panel of the A15 CPU board. Torque these screws to 9 in-lbs.
4. Re-connect the hard disk drive assembly (HDDA) ribbon cable and interface board to the A15 CPU board by reinstalling the two screws (item ①).

**Figure 16 A15 CPU Board Reinstallation**

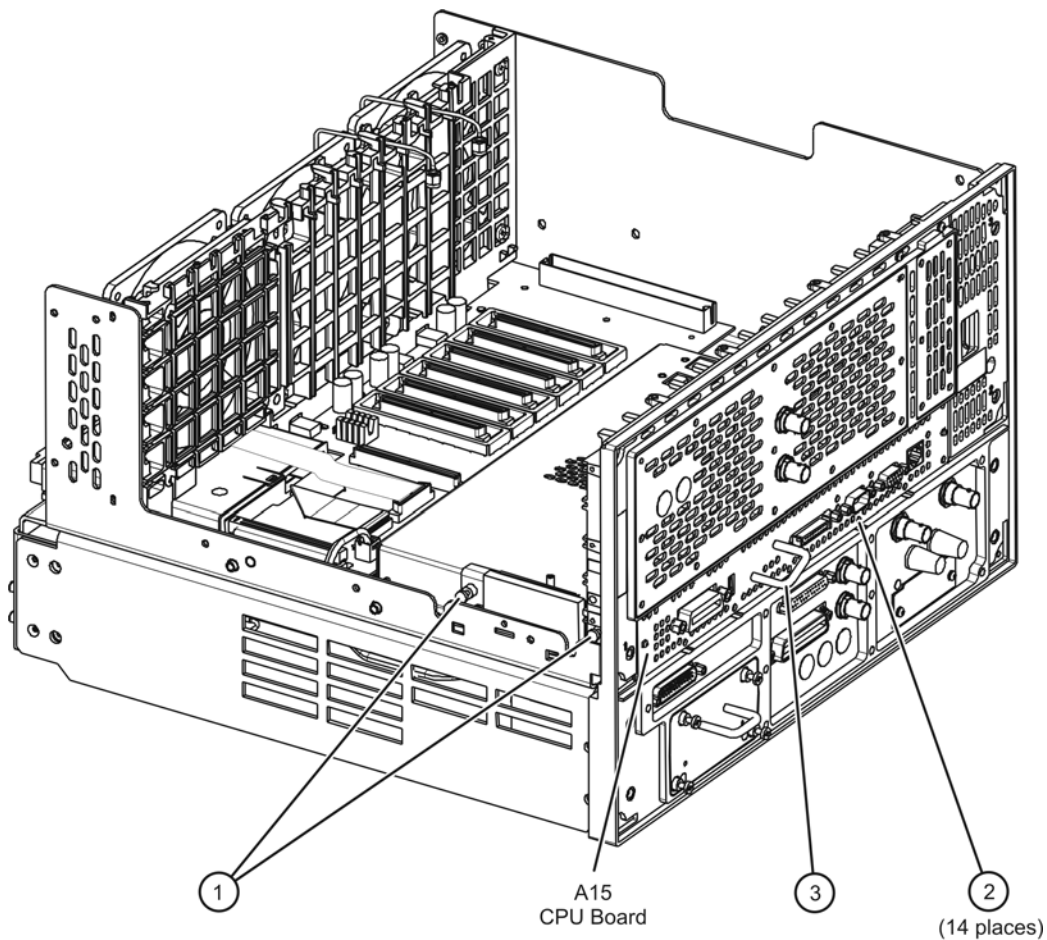

n5230\_019\_22

## Reinstall the Card Cage Boards (A5 through A10)

Refer to [Figure 18](#) for this part of the procedure. New parts are listed in [Table 1 on page 4](#).

1. Reinstall the A5 SPAM board, the A6 LO multiplier board, the A8 source multiplier board, and the A10 frequency reference board by aligning each of them with the proper slots and pushing them firmly downward to fully engage the motherboard connectors.

Make sure the two board extractors (item ①), located at each end of each board, are in the down position. Be especially careful of the top-to-bottom cables when reinstalling the boards. Do not over bend these cables.

2. Connect new flexible coax reference input cables, W71 and W72, to the bottom of the A7 and A9 synthesizer boards J105. Make sure the cable connectors are turned parallel to the boards (refer to [Figure 17](#)) so that they will not interfere with adjacent boards when they are reinstalled. Position these cables so that they can be routed between the boards to the front of the analyzer and over the midweb assembly where the cable hold down wire was removed.
3. Connect the new flexible coax cable W70 to the A10 frequency reference board J11 and route the cable to the rear of the analyzer for connection later.
4. Reinstall the A7 and A9 boards being careful not to pinch any of the cables beneath the boards and that the cables are properly routed to the front of the analyzer. The other end of these flexible coax cables will be connected later.
5. Reconnect all other flexible cables to the A5, A6, A7, A8, A9, and A10 boards.
6. Reinstall the semi-rigid synthesizer-multiplier jumper cables and torque the connectors to 10 in-lbs.
7. Connect the top-to-bottom cables, W3 and W6, and torque the connectors to 10 in-lbs. Turn the analyzer over and torque the other end of these two cables to 10 in-lbs. Turn the analyzer back over so that it is top-side up.
8. Do not reinstall the cable hold down wire at this time.

**Figure 17 Synthesizer Board Reference Input Cables Replacement**

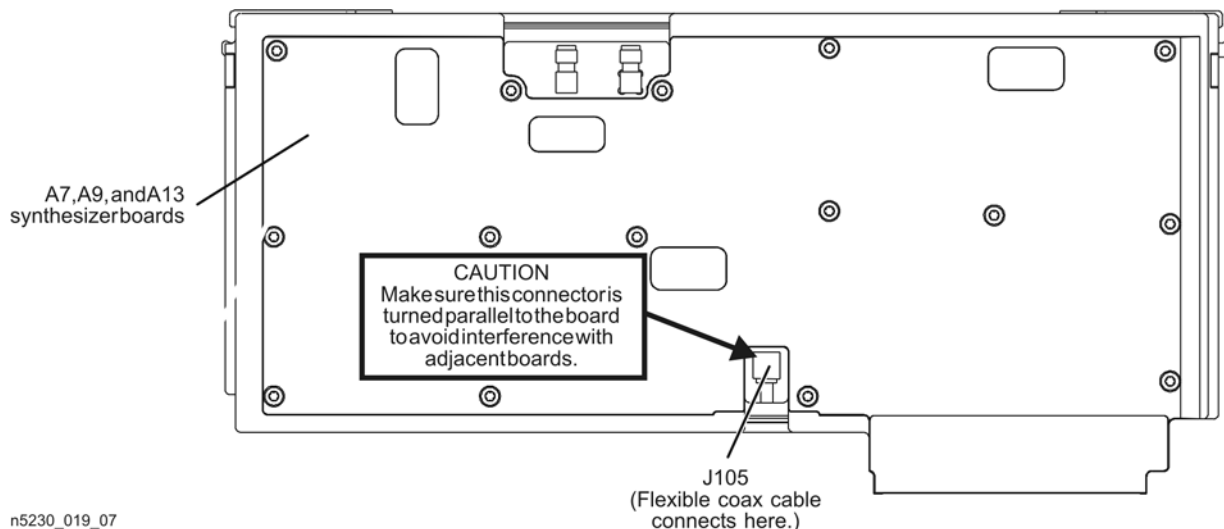

**Figure 18 Card Cage Boards Reinstallation**

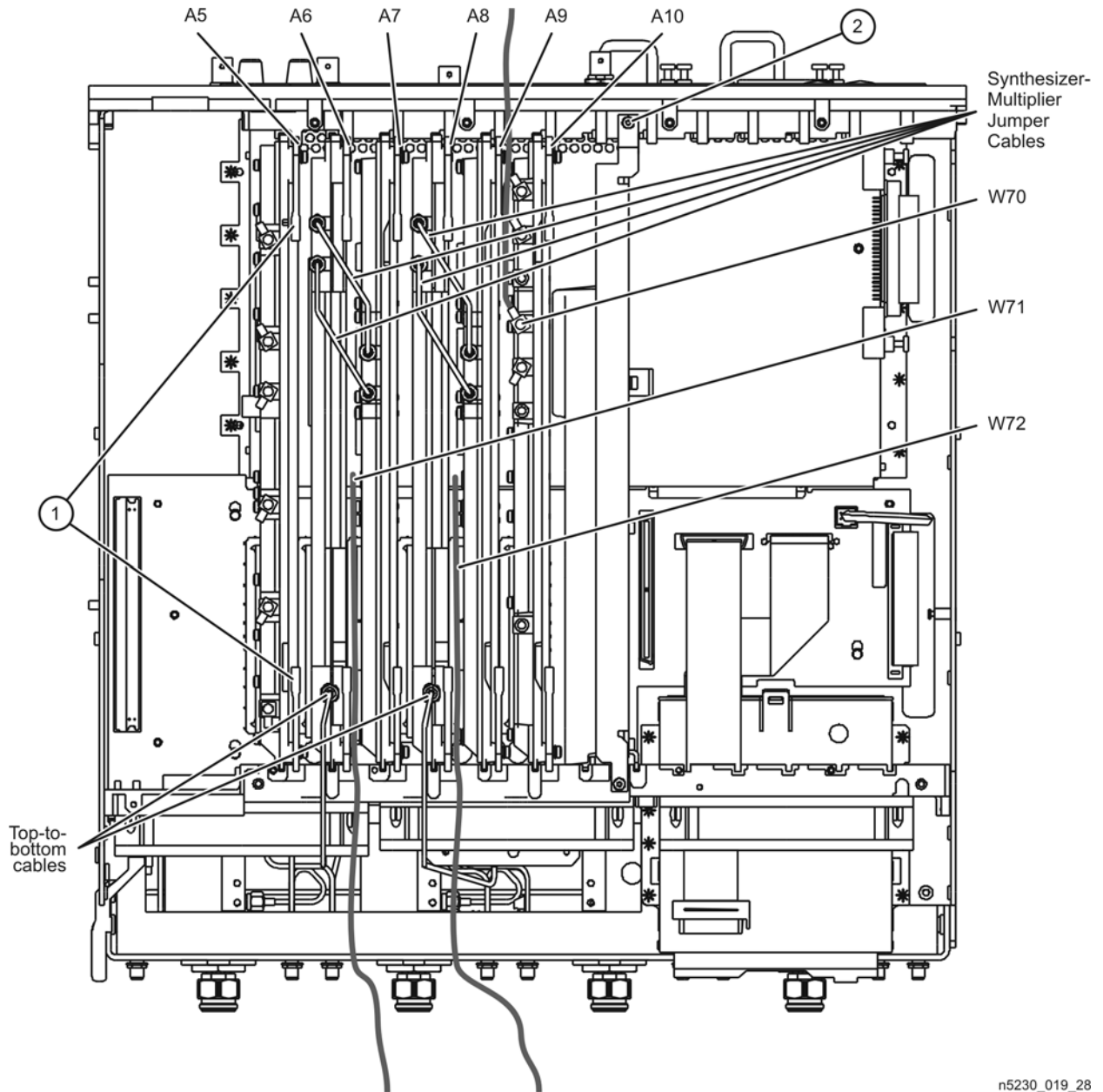

n5230\_019\_28

## Replace the Plenum Bracket (if necessary)

1. Visually determine if the plenum bracket looks like the one illustrated in [Figure 19](#) and includes the bump stop bracket as shown
  - If the plenum bracket DOES NOT include the bump stop bracket, then the plenum bracket must be replaced with the new one provided. Proceed to item 2 below.
  - If the plenum bracket installed DOES include the bump stop bracket, then skip items 2 and 3 below and continue at item 4 below to reinstall the plenum bracket.
2. Remove the three plenum attachment screws (item ③ in [Figure 19](#)) and remove the plenum from the plenum bracket. Discard the old plenum bracket.
3. Install the plenum onto the new plenum bracket provided (new parts are listed in [Table 1 on page 4](#)), using the three screws (item ③ in [Figure 19](#)) removed from the old plenum. Torque these screws to 9 in-lbs.
4. Reinstall the plenum bracket as shown in [Figure 20](#) and LOOSELY reinstall the retaining screws (item ①) and item ②) without the cable hold down wire. DO NOT TIGHTEN THE RETAINING SCREWS AT THIS TIME.

**Figure 19 Plenum Bracket Replacement**

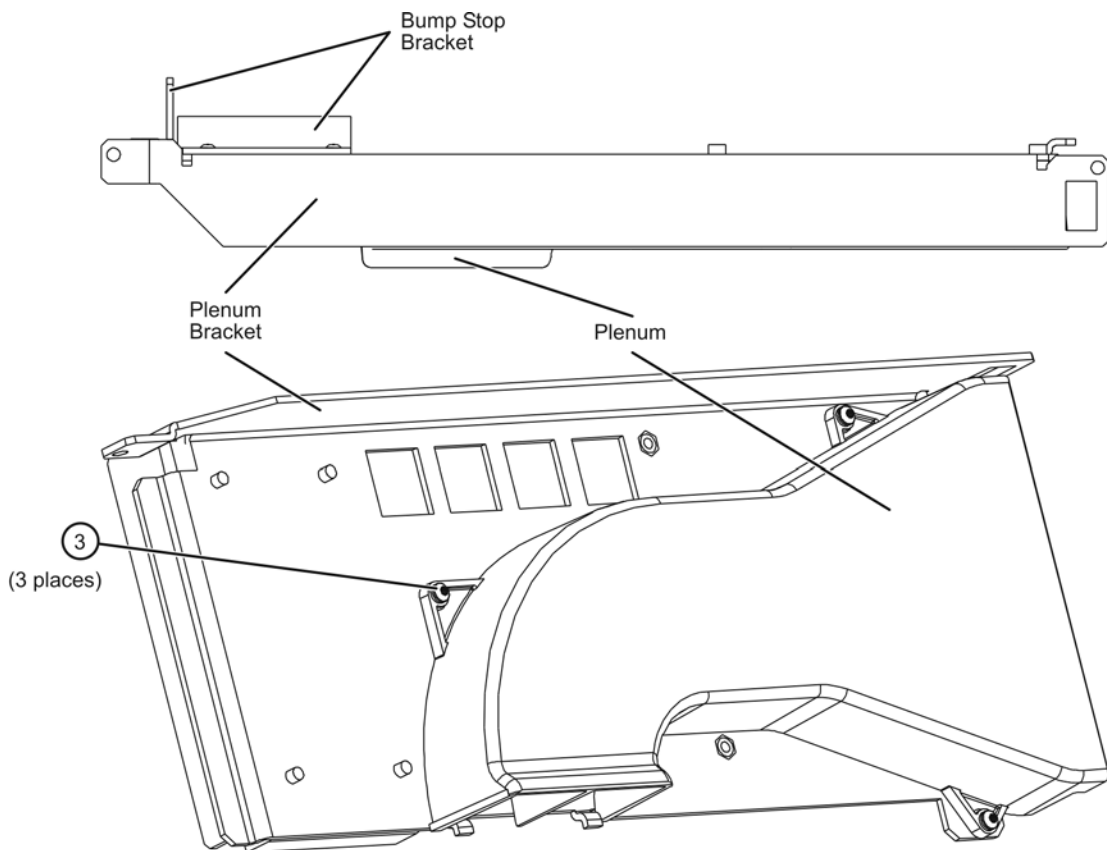

n5230\_019\_09

**Figure 20 Plenum Bracket Reinstallation**

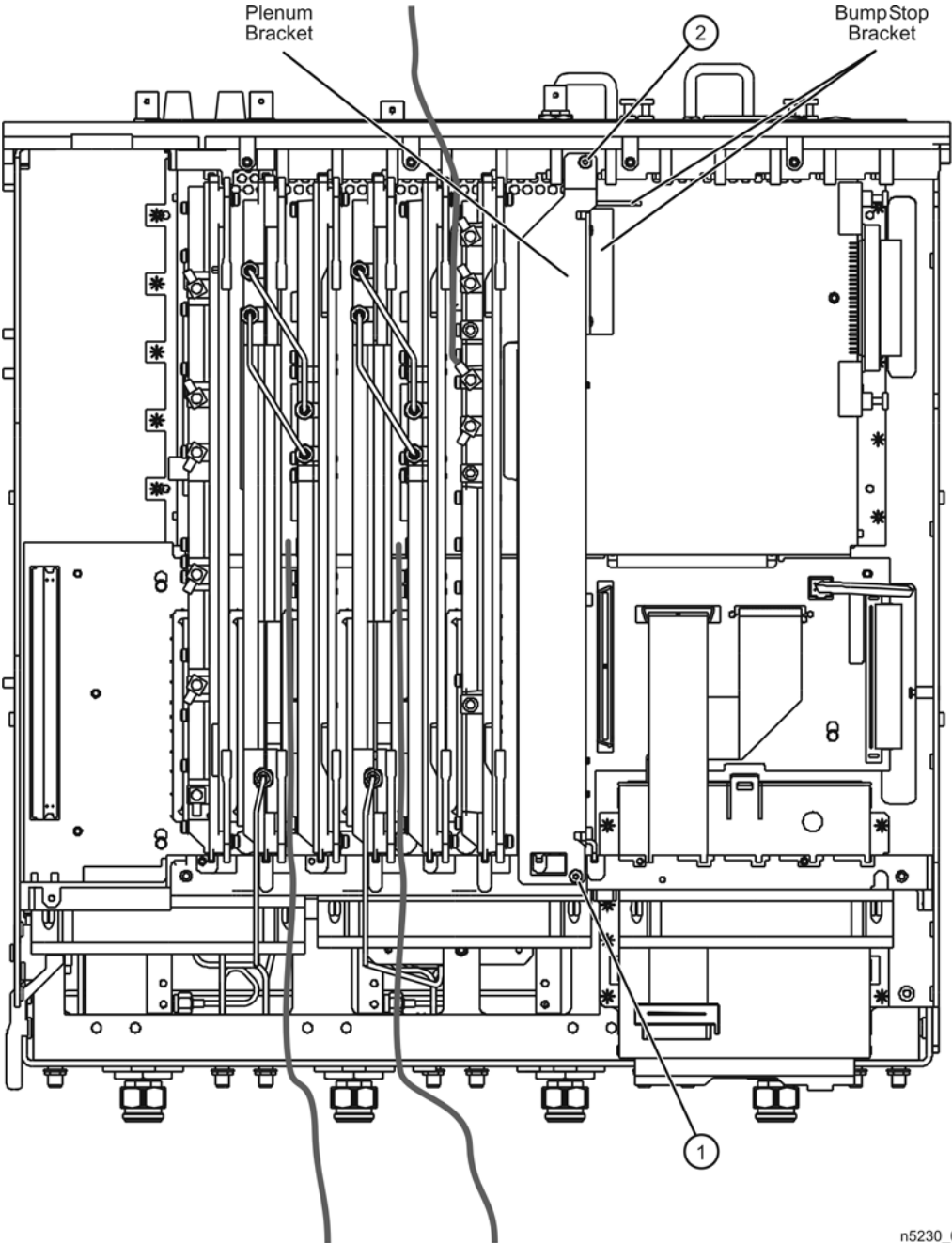

n5230\_019\_08

## Reinstall the A4 Power Supply Assembly

1. Insert the A4 power supply assembly into the analyzer as shown in [Figure 21](#).
2. With a T-10 TORX driver, reinstall the five screws (item ①) in the power supply assembly to secure it.

**Figure 21 A4 Power Supply Reinstallation**

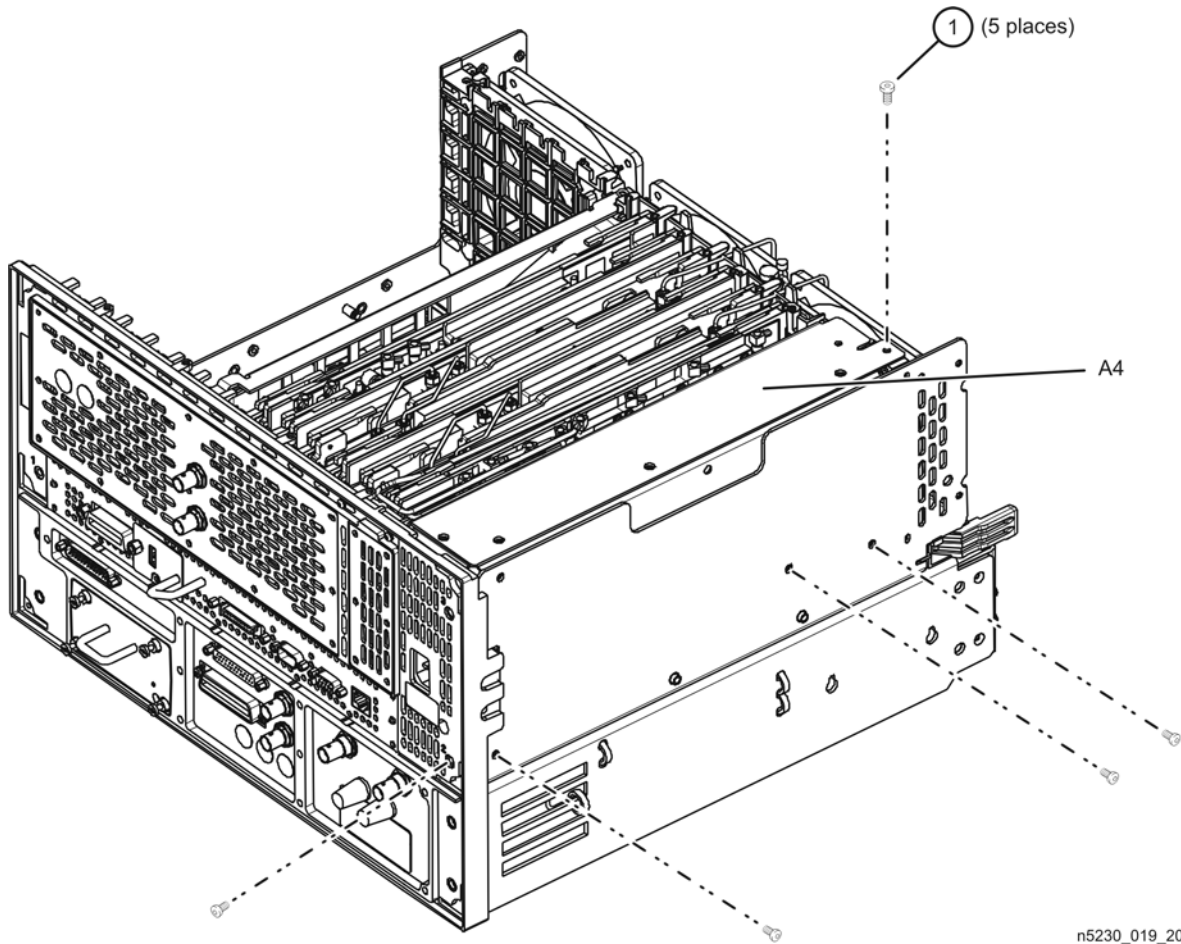

n5230\_019\_20

3. **Replacement of the A14 system motherboard is complete. Proceed to “[Step 6. Install the A29 Reference Switch](#)” on page 36.**

**Skip “[Step 4. Replace Reference Input Cables to Synthesizer Boards](#)” and “[Step 5. Replace the Plenum Bracket \(if necessary\)](#)” as these procedures have already been performed.**

## Step 4. Replace Reference Input Cables to Synthesizer Boards

(Perform only if the A14 system motherboard or the midweb assembly was not replaced.)

1. Remove the semi-rigid synthesizer-multiplier jumper cables shown in [Figure 23](#).
2. Remove the cable hold down wire retaining screw (item ①) and then remove the cable hold down wire.
3. Remove the A7 LO synthesizer board and the A9 source synthesizer board from the analyzer by lifting the board extractors indicated. Be careful not to damage any nearby cables. There is a flexible coax cable attached to the bottom (J105) of each of these synthesizer boards (refer to [Figure 22](#)) so the boards can only be extracted to a position just above the analyzer. Disconnect these cables from the A7 and A9 synthesizer boards and set the boards aside for reinstallation later.
4. Disconnect the other ends of these flexible coax cables from the A10 frequency reference board and discard them.
5. Connect new flexible coax reference input cables, W71 and W72, to the A7 and A9 synthesizer boards J105. New parts are listed in [Table 1 on page 4](#). Make sure the cable connectors are turned parallel to the boards (refer to [Figure 22](#)) so that they will not interfere with adjacent boards when they are reinstalled. Position these cables so that they can be routed between the boards to the front of the analyzer and over the midweb assembly where the cable hold down wire was removed.
6. Connect new flexible coax cable W70 to A10 frequency reference board J11 and route the cable over the rear frame of the analyzer for connection later.
7. Reinstall the A7 and A9 boards being careful not to pinch any of the cables beneath the boards and that the cables are properly routed to the front of the analyzer. The other end of these gray coax cables will be connected later.
8. Do not reinstall the cable hold down wire at this time.
9. Reinstall the synthesizer-multiplier jumper cables and torque to 10 in-lbs.

**Figure 22 Synthesizer Board Reference Input Cables Replacement**

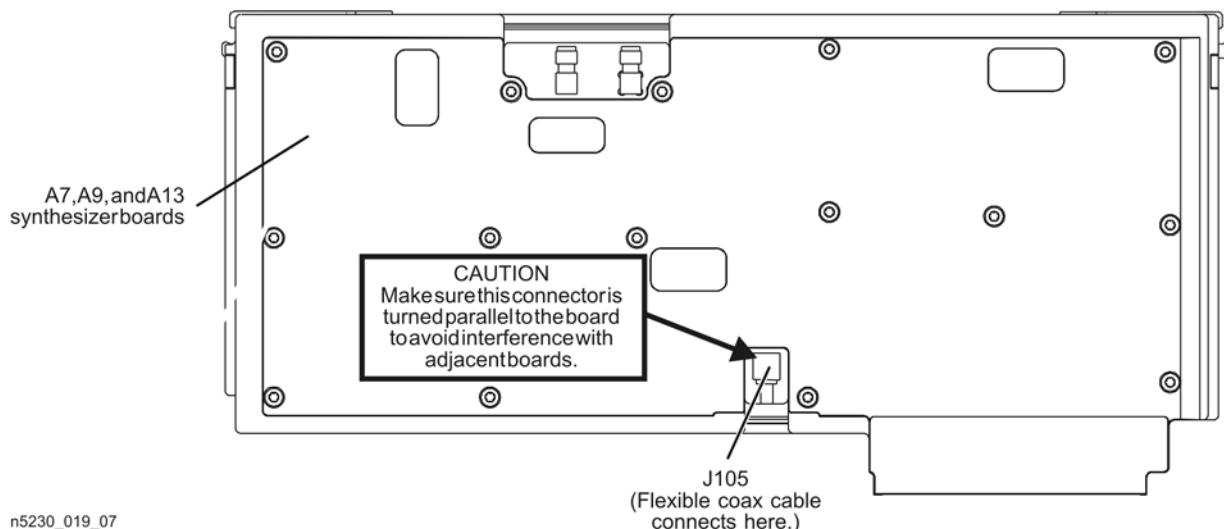

n5230\_019\_07



**Figure 23 A7 and A9 Synthesizer Board Removal and Reinstallation**

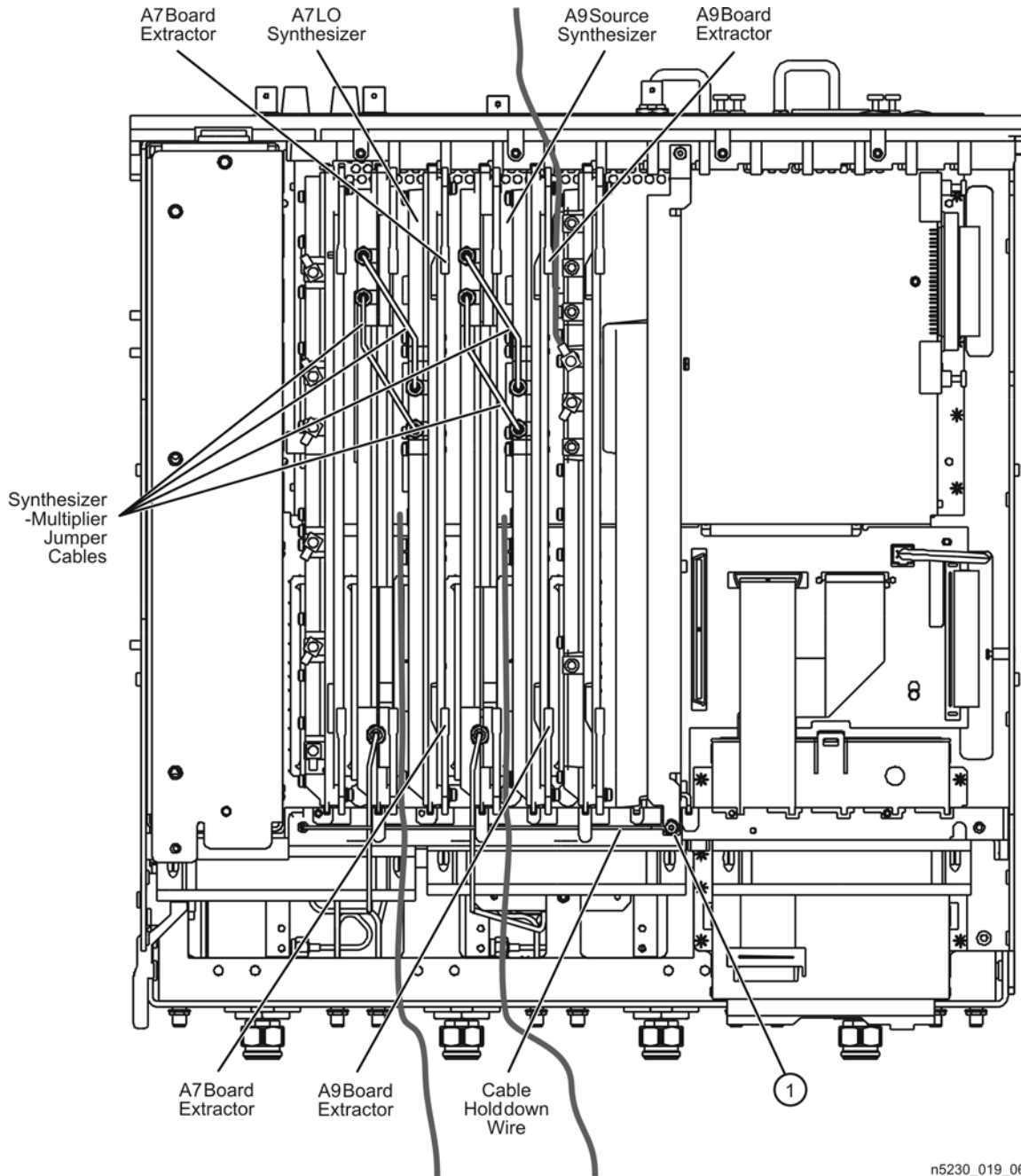

n5230\_019\_06

## Step 5. Replace the Plenum Bracket (if necessary)

(Perform only if the A14 system motherboard was not replaced.)

1. Visually determine if the plenum bracket looks like the one illustrated in [Figure 25](#) and includes the bump stop bracket as shown.
  - If the plenum bracket DOES NOT include the bump stop bracket, then the plenum bracket must be replaced with the new one provided. Proceed to item 2 below.
  - If the plenum bracket installed DOES include the bump stop bracket, then skip this step and proceed to “[Step 6. Install the A29 Reference Switch](#)” in the procedure.
2. Remove the retaining screw (item ②) from the plenum bracket as shown in [Figure 25](#) and remove the plenum bracket from the analyzer. The other retaining screw (item ①), that also holds the cable hold down wire, was removed in the previous step.
3. Remove the three plenum attachment screws (item ③ in [Figure 24](#)) and remove the plenum from the plenum bracket. Discard the old plenum bracket.
4. Install the plenum onto the new plenum bracket provided (new parts are listed in [Table 1 on page 4](#)), using the three screws (item ③ in [Figure 24](#)) removed from the old plenum. Torque these screws to 9 in-lbs.
5. Reinstall the plenum bracket and LOOSELY reinstall the retaining screws (item ① and item ②) without the cable hold down wire. DO NOT TIGHTEN THE RETAINING SCREWS AT THIS TIME.

**Figure 24 Plenum Bracket Replacement**

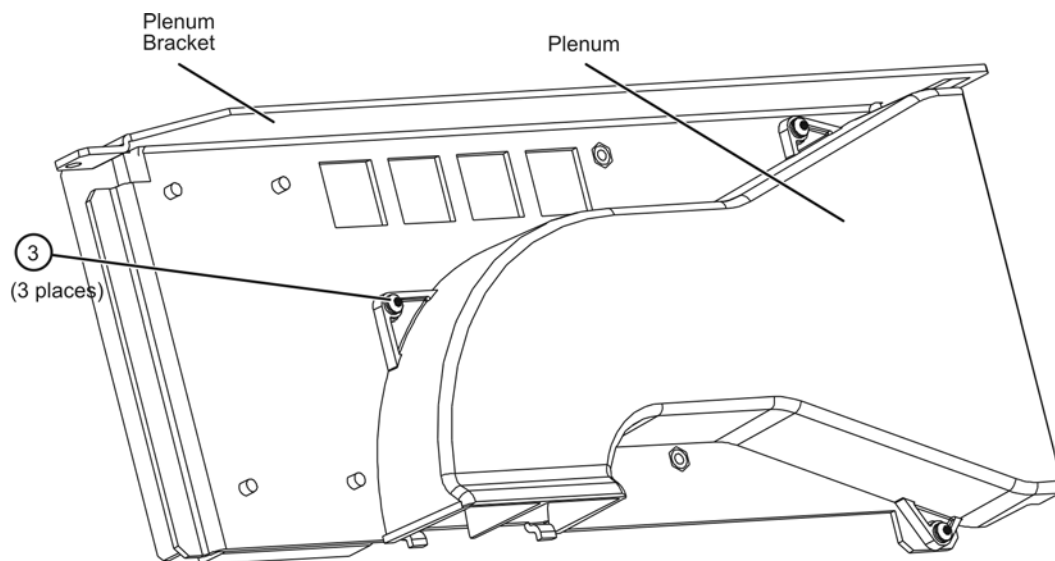

n5230\_019\_27

**Figure 25 Plenum Bracket Removal and Reinstallation**

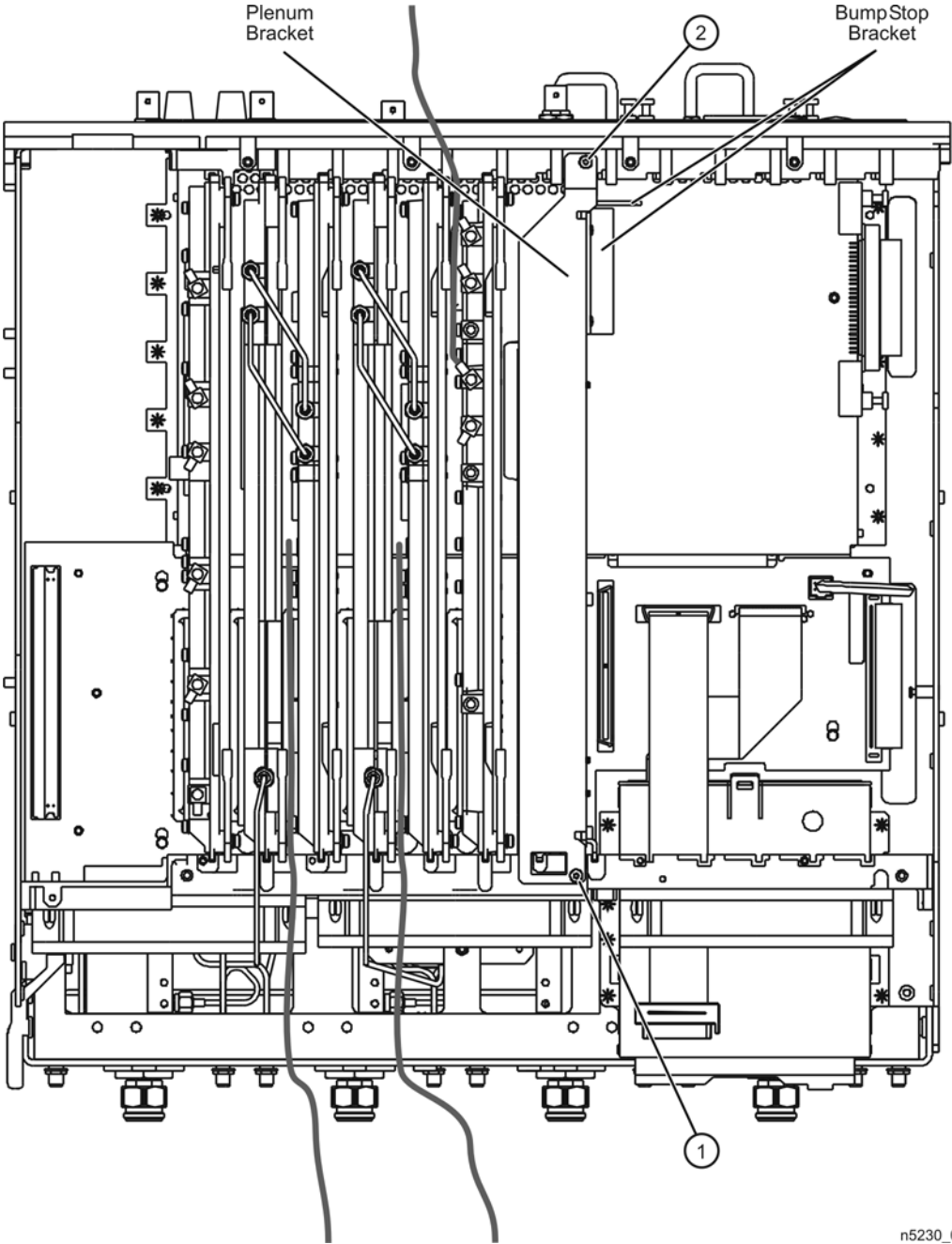

n5230\_019\_08

## Step 6. Install the A29 Reference Switch

Refer to [Figure 26](#) for this part of the procedure. New parts are listed in [Table 1](#) on page 4.

1. Place the analyzer bottom-side up on a flat surface as shown.
2. Install the reference switch mounting bracket onto four standoffs using three screws (item ①), as indicated.
3. Install the A29 reference switch onto the mounting bracket using two screws (item ②), as indicated.

**Figure 26 A29 Reference Switch Installation**

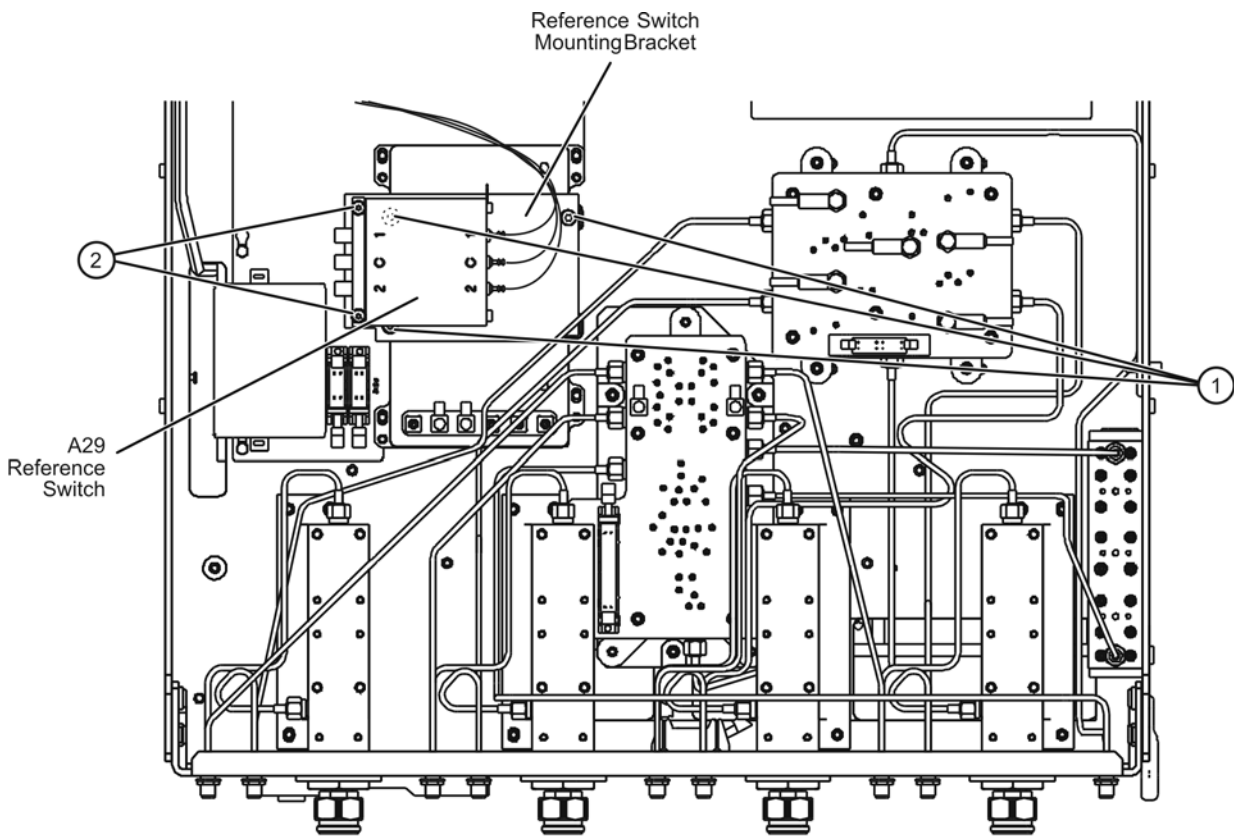

n5230\_019\_03

## Step 7. Remove the Existing Source Cables and Install Loads

Refer to [Figure 27](#) for this part of the procedure. New parts are listed in [Table 1 on page 4](#).

1. Remove cables W43, W42, and W48, as indicated.
2. Install 50 ohm loads (terminations) on the A19 MASSQuad ports where W42 and W43 were removed, as indicated.

**Figure 27 Existing Source Cable Removal and Loads Installation**

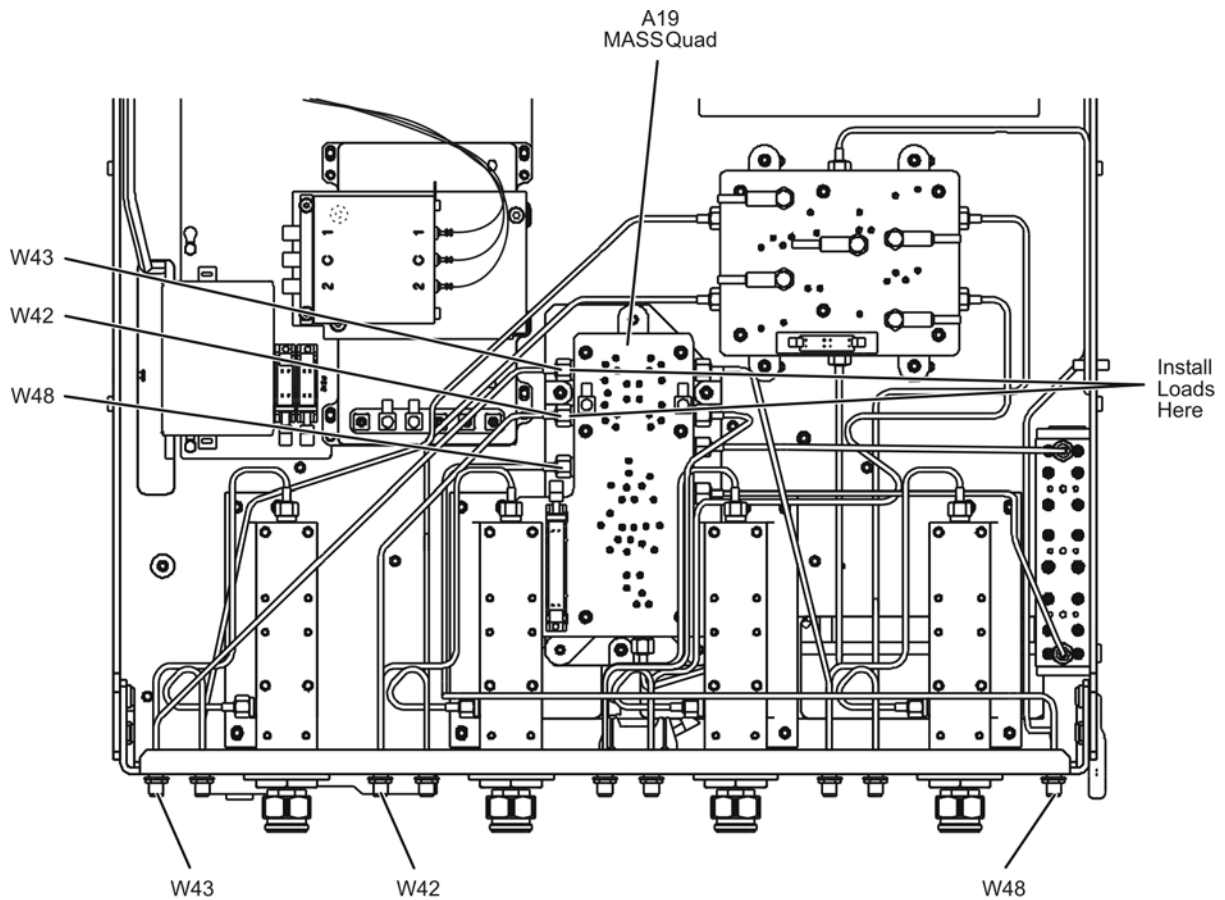

n5230\_019\_04

## Step 8. Install Limiter, DC Block, and A29 Reference Switch Cables

Refer to [Figure 28](#) for this part of the procedure. New parts are listed in [Table 1 on page 4](#).

1. Hand tighten the DC block onto the limiter and then, using a 5/16-in wrench to hold the hex nut on the limiter, use a 5/16-in torque wrench set to 10 in-lbs to fully tighten the DC block connector to the limiter.
2. Install W68 Switch-to-Limiter cable onto the limiter and, while holding the cable end with a 1/4-in wrench, torque the cable connector onto the limiter connector to 10 in-lbs.
3. Place the limiter, with the DC block and W68 Switch-to-Limiter cable attached, onto the tie mount provided and secure it LOOSELY with a cable tie. DO NOT FULLY TIGHTEN THE CABLE TIE AT THIS TIME.
4. LOOSELY connect the other end of W68 Switch-to-Limiter cable to the center port of the A29 reference switch. DO NOT FULLY TIGHTEN THIS CONNECTOR AT THIS TIME.
5. Remove the adhesive backing from the tie mount and, with the limiter positioned as shown, adhere the tie mount to the metal shield directly below it, as shown.
6. Fully tighten the cable tie around the limiter to fasten it securely.
7. Torque W68 Switch-to-Limiter cable to the A29 reference switch center port to 10 in-lbs.
8. Install new W66 MASSQuad-to-Switch cable from the open port on the A19 MASSQuad (next to the loads installed previously) to port 1 on the A29 reference switch, as shown.
9. Remove the existing front panel-to-mixer brick cable between front-panel REFERENCE RCVR IN and the A20 mixer brick (R) connector. Before cutting the four cable ties that secure the cable to the side frame, note their locations for installing new cable ties.
10. Install the new W80 front panel-to-mixer brick cable between front-panel REFERENCE RCVR IN and the A20 mixer brick (R) connector, as shown. Torque the connector nut at the front panel to 21 in-lbs and torque the A20 mixer brick (R) connection to 10 in-lbs. Secure the cable to the side frame with four new cable ties, in the locations noted when removing the old cable ties.
11. Install new W69 Limiter-to-Front Panel cable between the DC block and front-panel REFERENCE SOURCE OUT. Torque the connector nut at the front panel to 21 in-lbs and torque the DC block connection to 10 in-lbs.

**Figure 28 Limiter, DC Block, and Reference Switch Cable Installation**

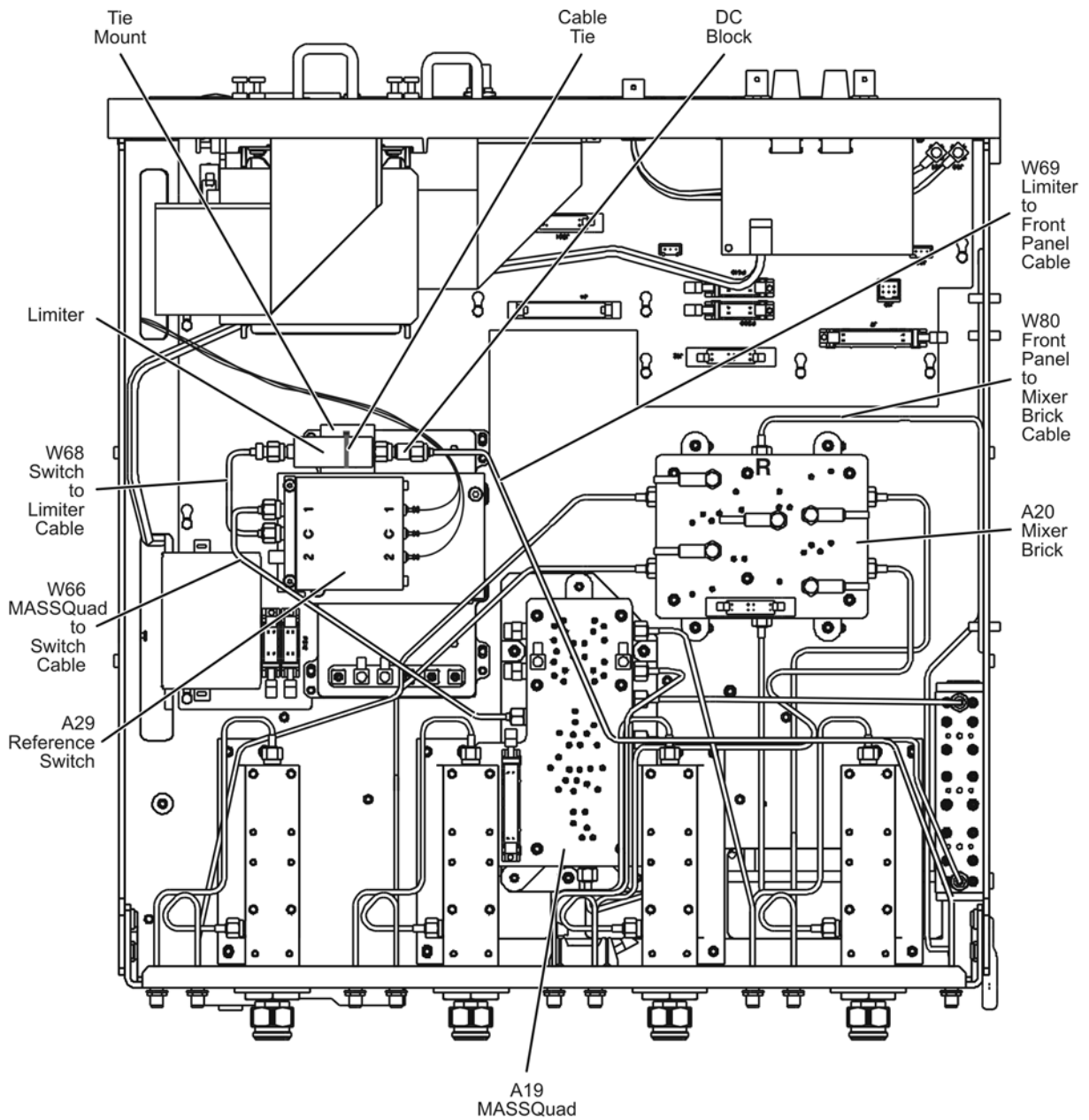

n5230\_019\_05

## Step 9. Install A11 Vertical Motherboard

All new parts are listed in [Table 1 on page 4](#).

1. Insert the A11 vertical motherboard into the A14 system motherboard connector, as shown in [Figure 29](#), so that it is aligned with the six standoffs on the plenum bracket. The plenum bracket has not been securely fastened at this point, so can be moved slightly to help align the standoffs with the A11 vertical motherboard screw holes.
2. Install six attachment screws (item ①) to secure the A11 vertical motherboard to the plenum bracket. Torque these screws to 9 in-lbs.

**Figure 29 A11 Vertical Motherboard Installation**

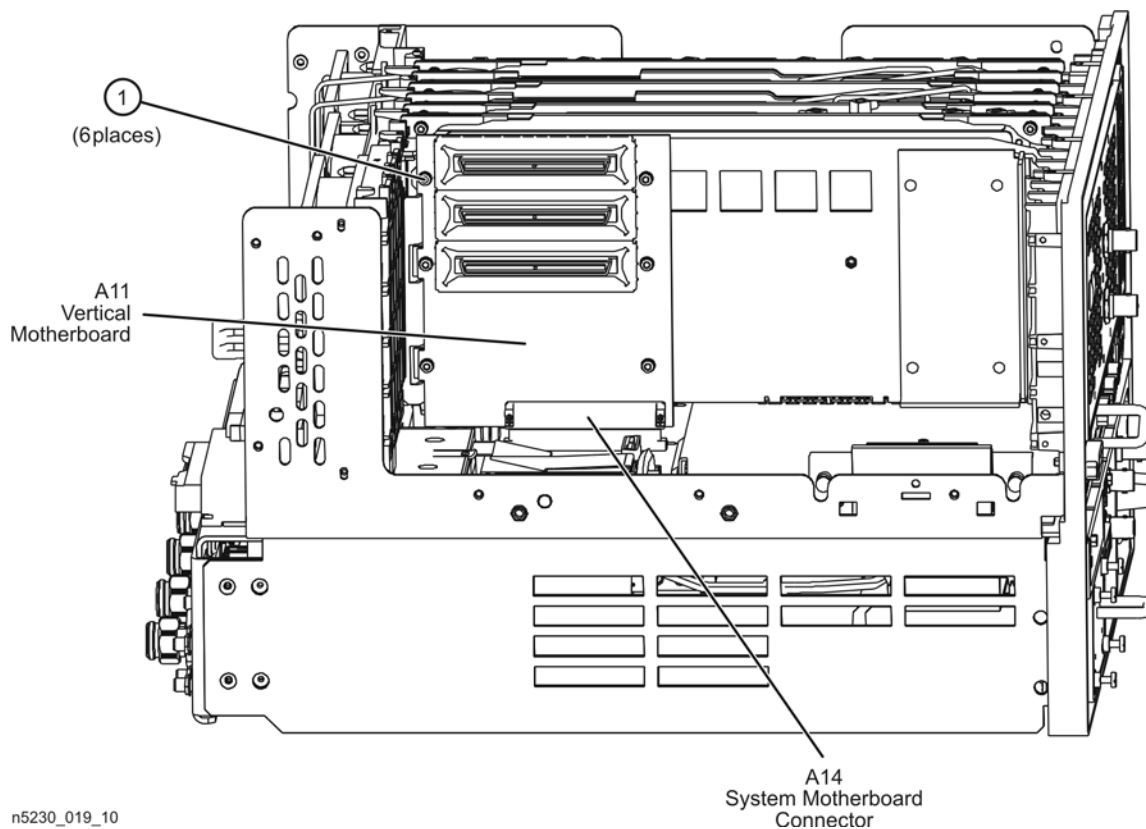



## Step 10. Attach A18 MASSQuad and A26 Step Attenuator to the A17 QABC Board

All new parts are listed in [Table 1 on page 4](#).

1. Position the A26 step attenuator on the A17 QABC board, as shown in [Figure 30](#), and secure it with two screws (item ①). Torque these screws to 9 in-lbs.
2. Position the A18 MASSQuad on the A17 QABC board as shown and secure it with three attachment screws (item ②). Torque these screws to 9 in-lbs.

**Figure 30 A17 QABC Assemblies Installation**

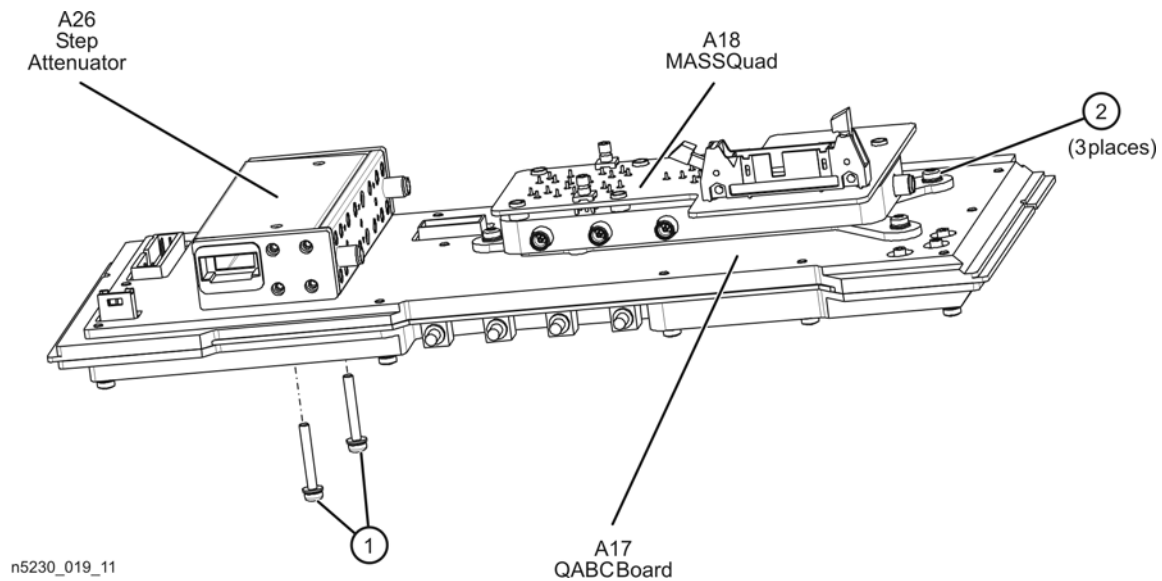

## Step 11. Install Cables on the A17 QABC Board

All new parts are listed in [Table 1 on page 4](#).

1. Install two 50 ohm loads in the locations indicated in [Figure 31](#) and torque the connectors to 10 in-lbs.
2. Install cables W78 and W79 and torque the connectors to 10 in-lbs.
3. Install flexible coax cables W74 and W75 between the connectors indicated.
4. Install ribbon cable (item ①) between the attenuator and board connector P512 as shown. Be careful to align the notches on the cable connector with the notches on the mating connector. Install a retainer clip on the P512 connector as indicated.
5. Install ribbon cable (item ②) between A18 MASSQuad J4 and A17 QABC board J4 as shown. Install a retainer clip on the A17 QABC board J4 connector as indicated.
6. Install cable W63 in the position and orientation shown. Torque the connector to 10 in-lbs. The other end will be connected later.

**Figure 31 A17 QABC Cables Installation**

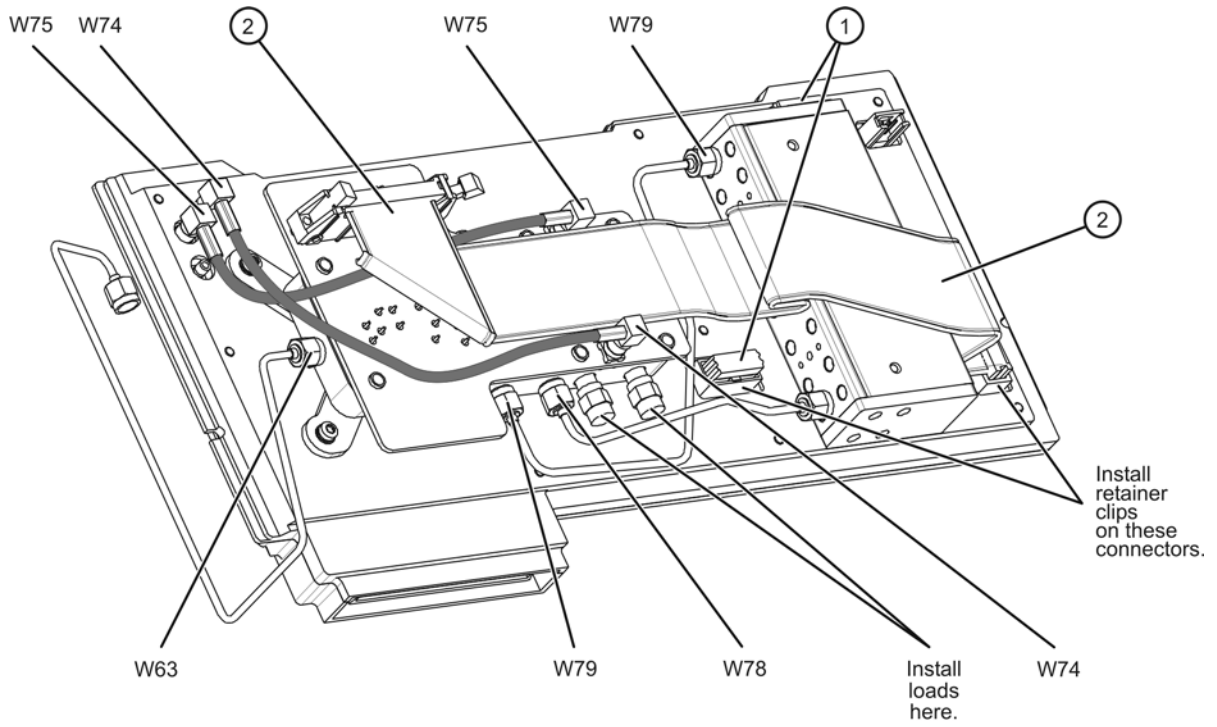

n5230\_019\_12

## Step 12. Install the A17 QABC Board

1. Position the analyzer on its left side, as shown in [Figure 33](#), so that the interior of the analyzer is accessible from the top, bottom, and right side. All new parts are listed in [Table 1 on page 4](#).
2. Install the A17 QABC board in the third slot from the top, as shown in [Figure 32](#), making sure that it is firmly seated in the A11 vertical motherboard connector.
3. Route the A29 reference switch control cable from the bottom side of the analyzer through the opening indicated in both [Figure 32](#) and [Figure 33](#) and connect it to connector J10 on the A17 QABC board as shown.
4. Connect flexible coax cables W70 to J800, W71 to J801, and W72 to J802 and route them as shown. The other end of cables W71 and W72 are connected to the A7 and A9 synthesizer boards. The other end of cable W70 is connected to the A10 frequency reference board J11.
5. Route semirigid cables W64, W65, and W67 through the opening indicated in [Figure 32](#) and [Figure 33](#). Loosely connect W64, W65, and W67 to the A18 MASSQuad as shown. **DO NOT TIGHTEN THE CONNECTOR NUTS AT THIS TIME.**
6. Connect the other end of W64 to front panel PORT 3 SOURCE OUT on the bottom side of the analyzer. Torque the connector nut to 21 in-lbs.
7. Connect the other end of W65 to front panel PORT 4 SOURCE OUT on the bottom side of the analyzer. Torque the connector nut to 21 in-lbs.
8. Connect the other end of W67 to Port 2 of the reference switch on the bottom side of the analyzer. Torque the connector nut to 10 in-lbs.
9. Go back and torque the connector nuts on the other ends of W64, W65, and W67 at the A18 MASSQuad to 10 in-lbs.

**Figure 32 A17 QABC Board Installation**

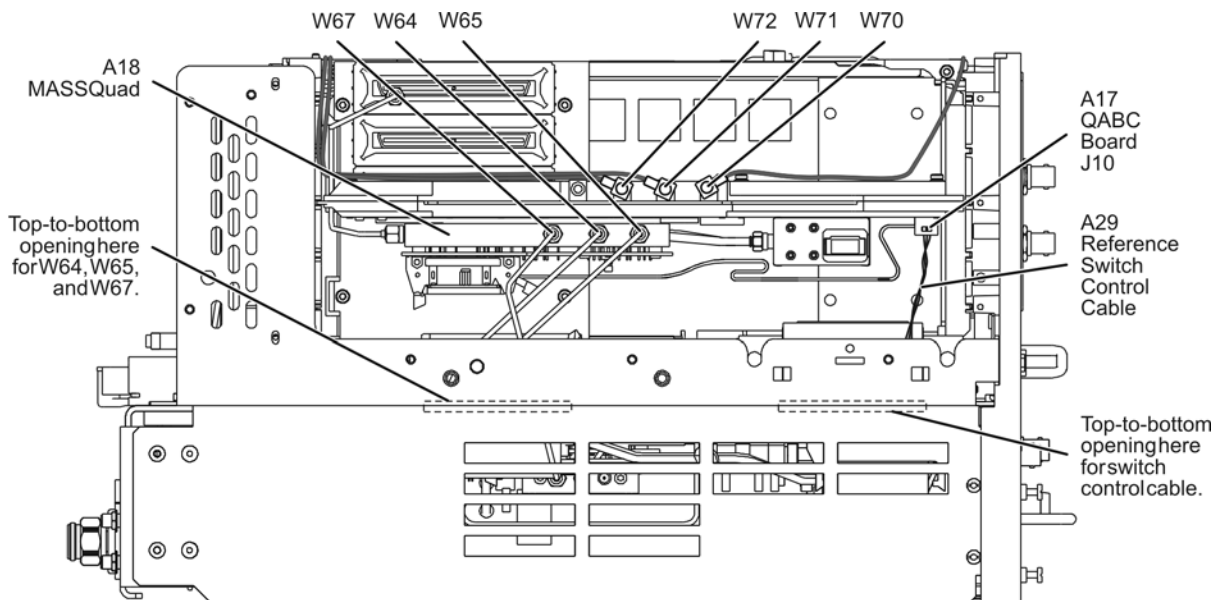

n5230\_019\_14

**Figure 33 A17 QABC Board Installation**

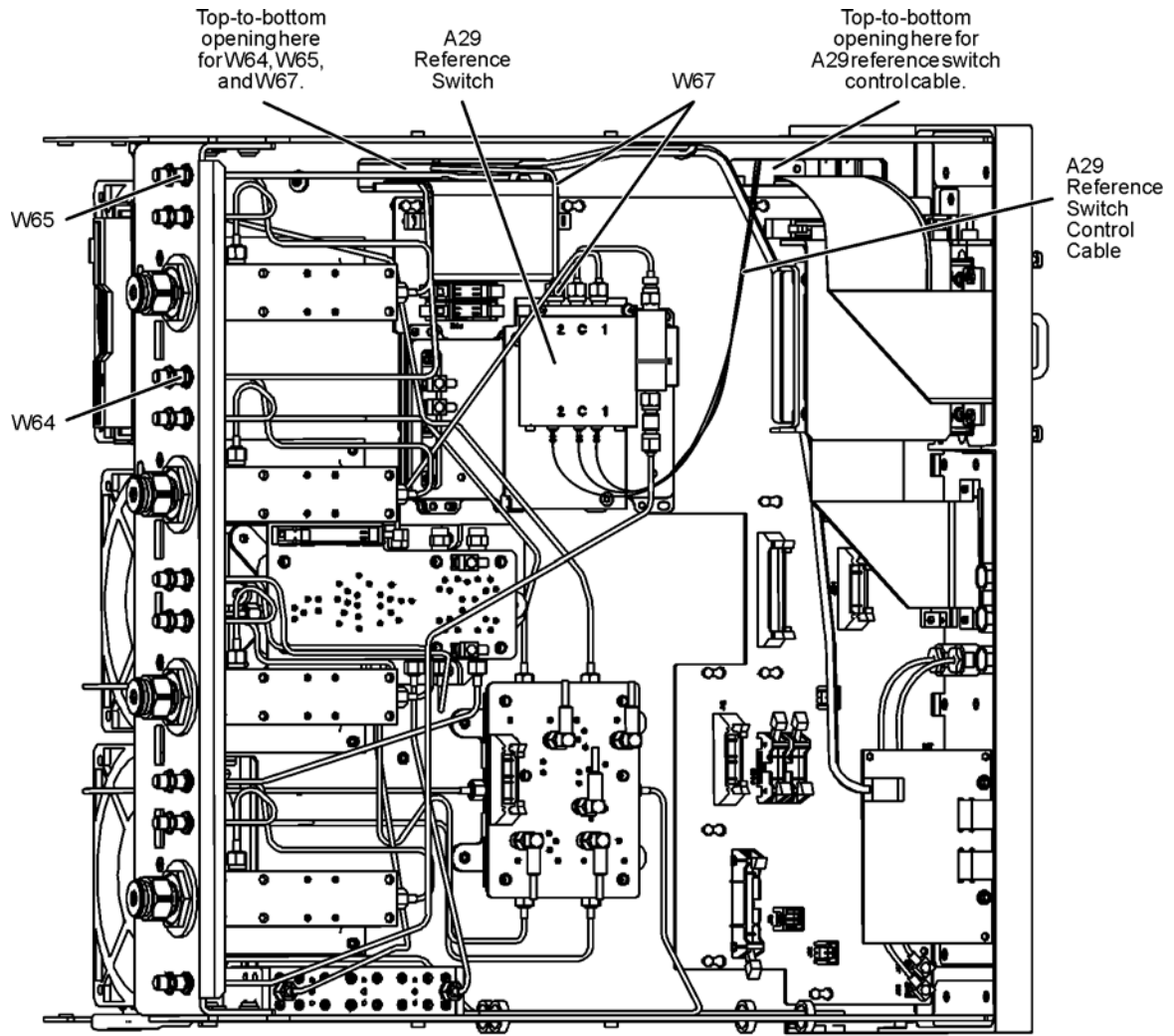

n5230\_019\_13

## Step 13. Install the A12 Multiplier and A13 Synthesizer Boards

All new parts are listed in [Table 1 on page 4](#).

1. While holding semirigid cable W63 out of the way, slide the A12 multiplier board into the top slot, as shown in [Figure 34](#). Be careful not to damage the semirigid cable. Do not over-bend this cable as it can be permanently damaged.
2. Make sure the A12 multiplier board connector is firmly seated in the A11 vertical motherboard connector.
3. Connect W63 to the A12 multiplier board and torque the connector nut to 10 in-lbs.
4. Connect new reference input cable, W73, to J105 on the new A13 synthesizer board. Refer to [Figure 22 on page 32](#) for an illustration of the synthesizer board and the location of J105.
5. Position the new W73 cable on the back side of the A13 synthesizer board and, while holding the cable firmly, slide the A13 synthesizer board into the second slot from the top. Make sure that the cable is not pinched and that all connectors are free of interference.
6. Connect flexible cable W73 to connector J803 on the A17 QABC board as shown.
7. Install synthesizer-multiplier jumper cables, W61 and W62, between the A13 synthesizer board and the A12 multiplier board, as shown, and torque the connector nuts to 10 in-lbs.

**Figure 34 A12 and A13 Boards Installation**

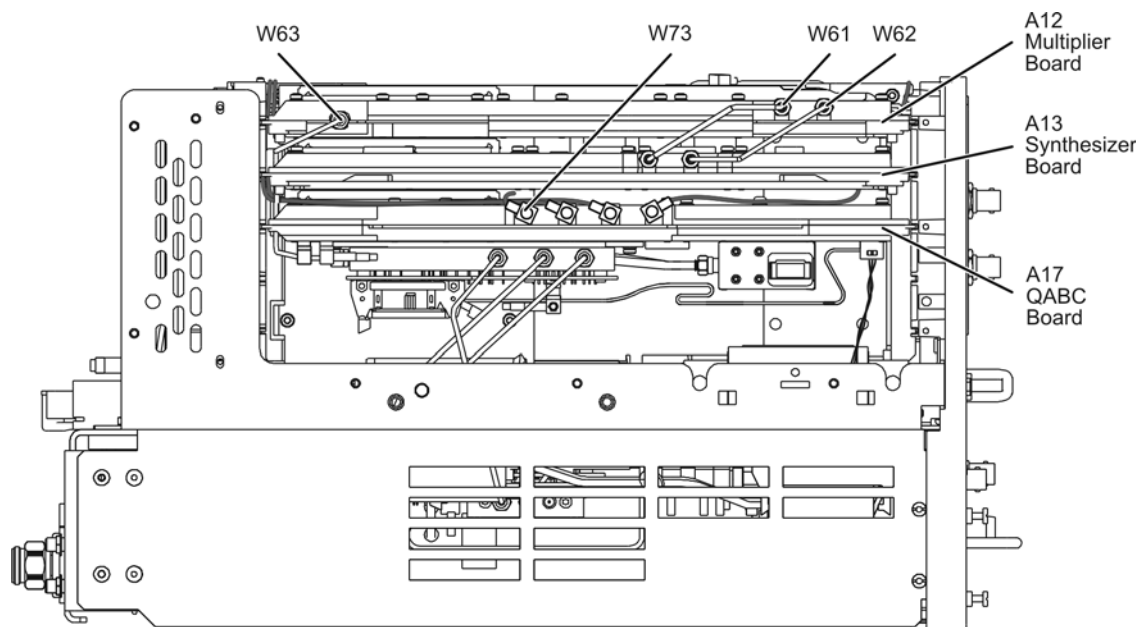

n5230\_019\_15

## Step 14. Position Flexible Cables and Reinstall Cable Hold Down Wire

1. Position the flexible gray coax cables, W70, W71, and W72, in the cable run areas at the front and rear of the analyzer as shown in [Figure 35](#).
2. Reinstall the cable hold down wire, making sure that all cables (including the ones installed in the previous steps) are properly routed beneath it and will not be pinched.
3. Torque the two cable hold down wire retaining screws (item ①) to 9 in-lbs.

**Figure 35 Flexible Cable Positioning and Cable Hold Down Wire Installation**

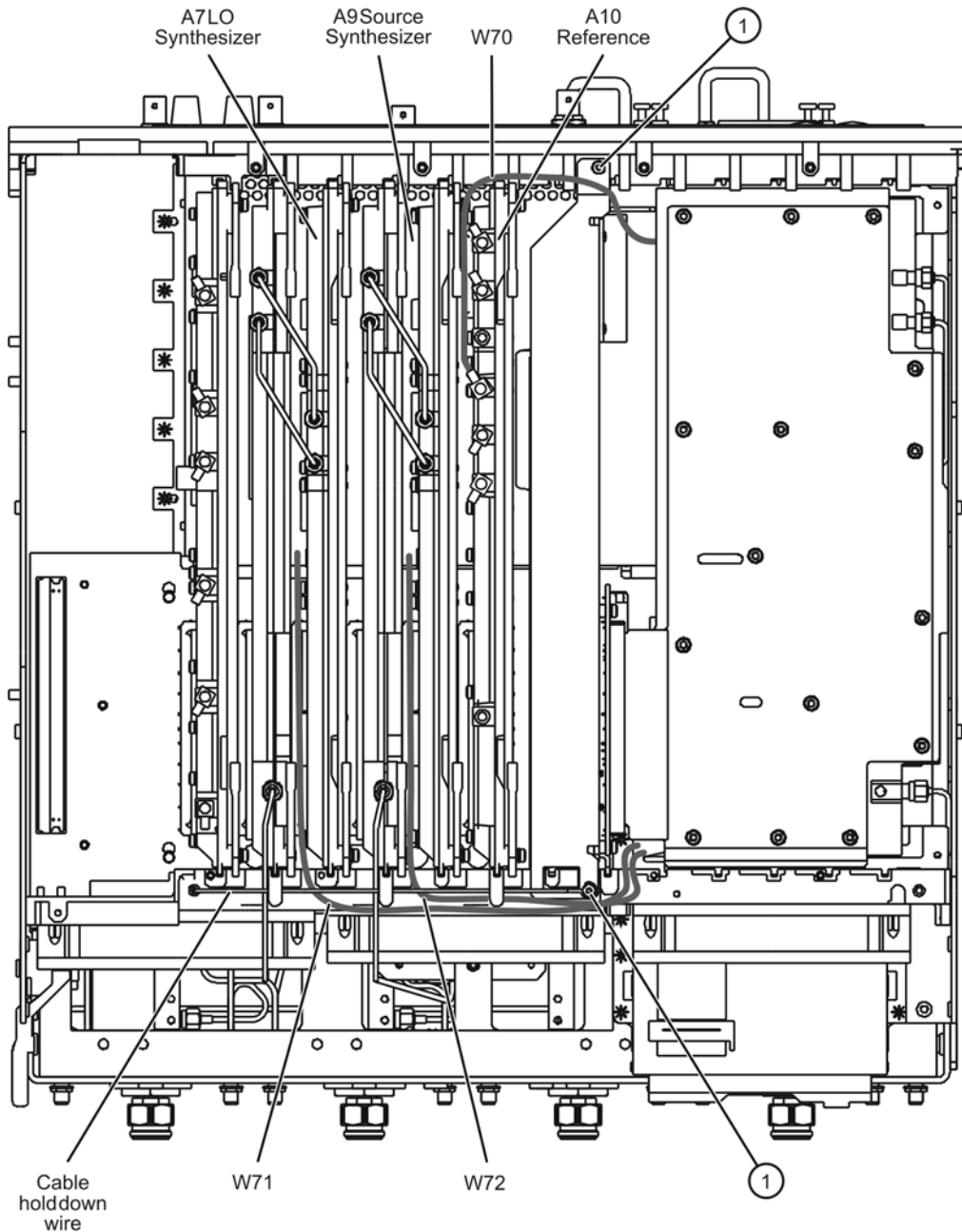

n5230\_019\_16

## Step 15. Reinstall the Front Panel Assembly and Front Panel Jumpers

**CAUTION** Before installing the front panel assembly onto the analyzer, lift and support the front of the analyzer chassis.

Refer to [Figure 36](#) for this procedure. New parts are listed in [Table 1 on page 4](#).

1. Make sure all 18 of the hex nuts on the front-panel cable connectors have been tightened using a 5/16-in torque wrench set to 21-in lbs.
2. Reconnect the ribbon cable (item ③) to the A3 front panel interface board.
3. Slide the front panel over the test port connectors being careful to align the power switch and floppy disk drive to their corresponding front panel cutouts. Ensure that the ribbon cable (item ①) is located below the fan to prevent it from being damaged by the fan blades.
4. With a T-10 TORX driver, install the eight screws (item ②) in the sides of the frame.
5. Install the nine semirigid jumpers (item ①) on the front panel, and tighten to 10-in lbs.

**Figure 36 Front Panel Assembly Reinstallation**

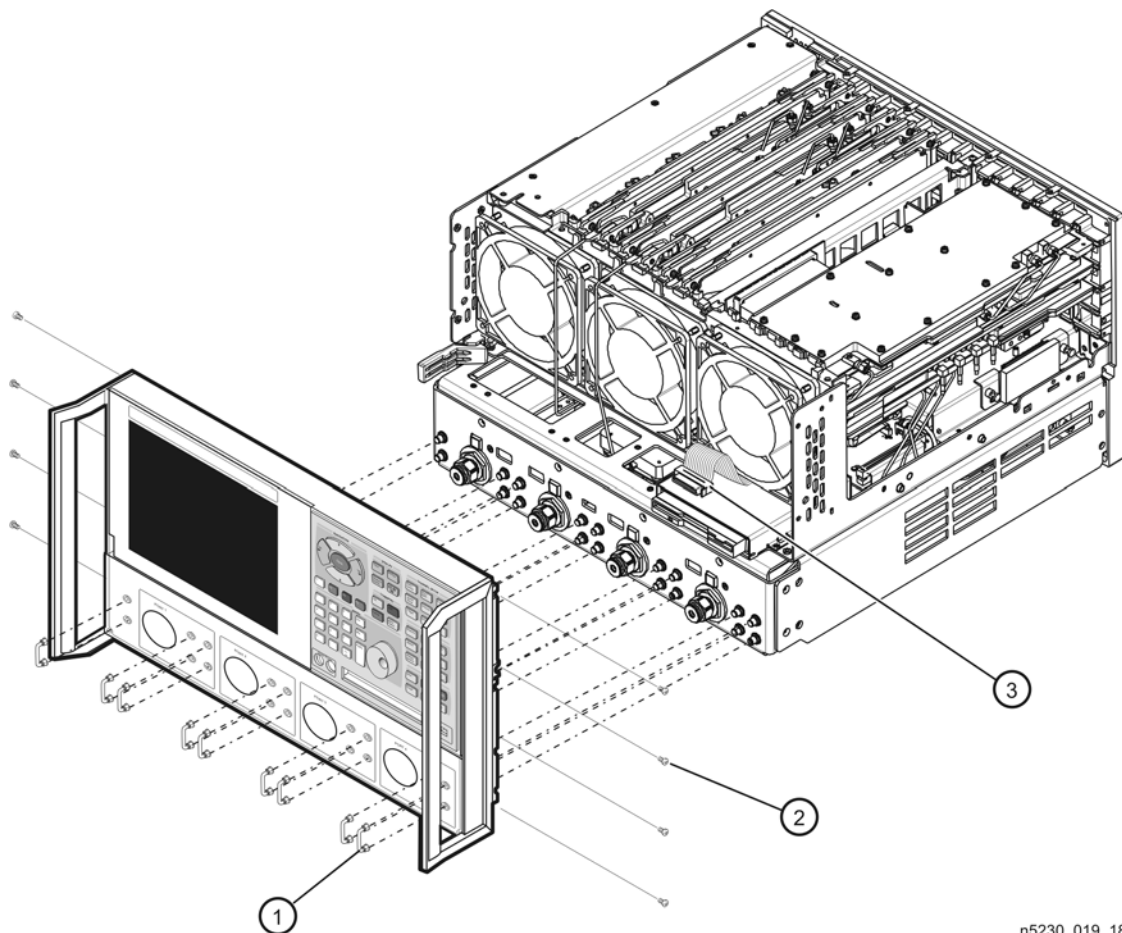

n5230\_019\_18



## Step 16. Modify the New Inner Cover

All new parts are listed in [Table 1 on page 4](#).

1. Remove the backing from the three retainer blocks (foam pads) provided and adhere them onto the inside of the inner cover in the locations shown in [Figure 37](#).

**Figure 37 Installation of New Retainer Blocks (Foam Pads)**

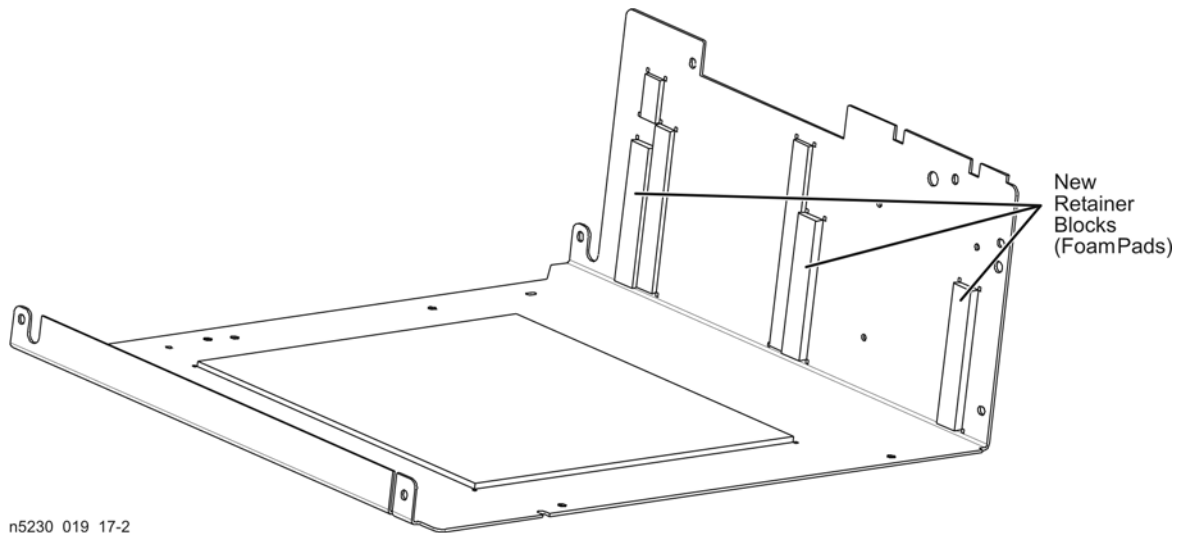

## Step 17. Install the New Inner and Outer Covers

### Install the New Inner Cover

Refer to [Figure 38](#) for this part of the procedure.

1. Make sure that the cover has been modified as directed in “[Step 16. Modify the New Inner Cover](#)” on page 49.
2. Position the new inner cover provided on the analyzer as shown.
3. With a T-10 TORX driver, reinstall the cover attachment screws (item ⑥) and (item ⑦).

**Figure 38 Inner Cover Reinstallation**

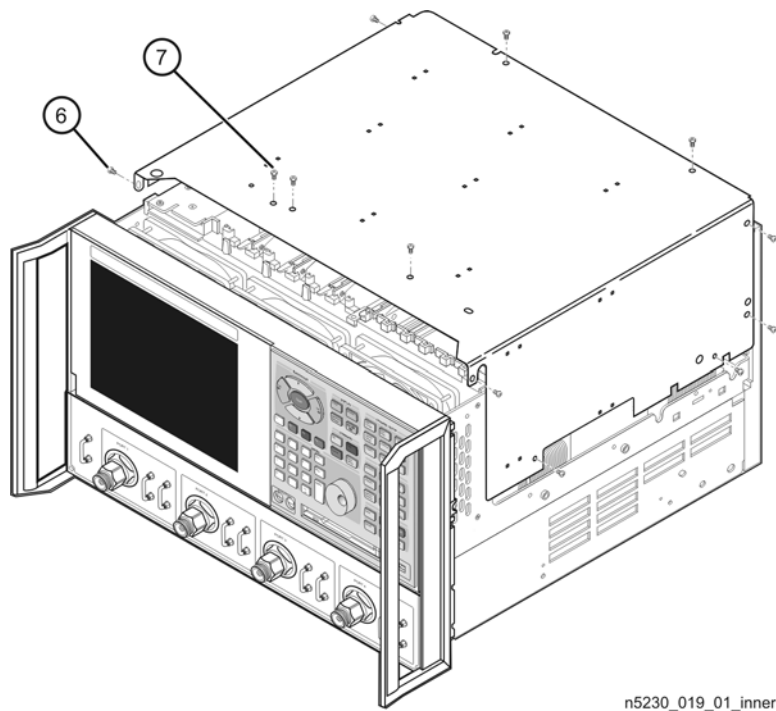

## Install the New Outer Cover

Refer to [Figure 39](#) for this part of the procedure.

---

**CAUTION** Installing the outer cover is best performed with the analyzer resting on its front handles in the vertical position. *Do not place the analyzer on its front panel without the handles.* This will damage the front panel assemblies.

---

1. Slide the new outer cover provided onto the frame. It is imperative that you use the new cover provided. Do not reuse the old cover. Discard it.
2. Slide the four bottom feet (item ⑤) onto the cover.
3. Install the four rear panel feet (item ③) by reinstalling the center screws (item ④) with a T-20 TORX driver,.
4. Reinstall the strap handles (item ①) by tightening the screws (item ②) on both ends with a T-20 TORX driver.
5. Reconnect the power cord.

**Figure 39 Outer Cover Reinstallation**

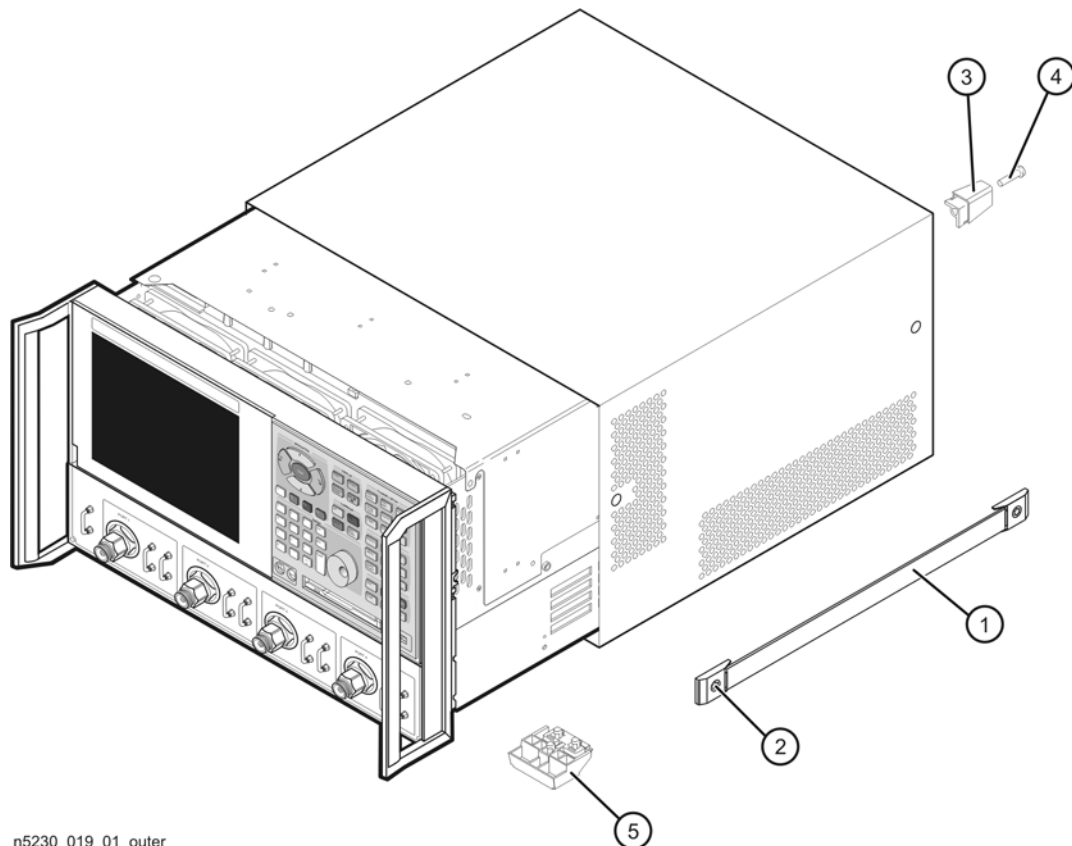

## Step 18. Enable Option S02

### Procedure Requirements

- The analyzer must contain firmware revision code 7 or higher.
- The analyzer must be powered up and operating to perform this procedure.
- The Network Analyzer program must be running.
- A mouse must be connected to the analyzer for this procedure.

### Option Enable Procedure

1. On the analyzer's **System** menu, point to **Service**, and then click **Option Enable**.
2. In the **Select Desired Option** list, click **S02 - Second Source**. Click **Enable**.
3. Click **Yes** in answer to the displayed question in the **Restart Analyzer?** box.
4. When the installation is complete, click **Exit**.

### Option Verification Procedure

Once the analyzer has restarted and the Network Analyzer program is again running:

1. On the analyzer's **Help** menu, click **About Network Analyzer**.
2. Verify that "146" (for a 13.5 GHz analyzer) or "246" (for a 20 GHz analyzer) is listed after "Options:" in the display. Click **OK**.

---

<b>NOTE</b>	If the proper option has not been enabled, perform the " <a href="#">Option Enable Procedure</a> " again. If the option is still not enabled, contact Agilent Technologies. Refer to " <a href="#">Getting Assistance from Agilent</a> " on page 3.
-------------	---

---

## Step 19. Perform Post-Upgrade Adjustments and Calibration

### Adjustments

The following adjustments must be made due to the hardware changes of the analyzer.

- source calibration
- receiver calibration

These adjustments are described in the PNA Service Guide and in the PNA on-line HELP. A list of equipment required to perform these adjustments can be found at [“Equipment Required for Post-Upgrade Adjustments” on page 7](#).

To view the Service Guide online, use the following steps:

1. Go to *www.agilent.com*.
2. In the Search box, enter N5230-90013 (the part number of the N5230A 4-Port PNA-L Service Guide) and click **Search**.
3. When the PDF of the Service Guide is displayed, scroll through the Contents section bookmarks to locate the “Tests & Adjustments” chapter.

After adjustment, the analyzer should operate and phase lock over its entire frequency range.

### Operator’s Check

Perform the Operator’s Check to check the basic functionality of the analyzer. For instructions, refer to the “Tests & Adjustments” chapter of the Service Guide.

If you experience difficulty with the basic functioning of the analyzer, contact Agilent. Refer to [“Contacting Agilent” on page 3](#).

### Calibration

Although the analyzer functions, its performance relative to its specifications has not been verified. It is recommended that a full instrument calibration be performed using the PNA performance test software. Refer to the analyzer’s service guide for information on the performance test software.

